



The Standard of Measurement

# TCS 3000 REGISTER



## Setup & Operation Manual Generation 2.0

# Table of Contents

Table of Contents	2		
Receipt & Inspection Notice	3		
Introduction	4		
System Specifications	4		
TCS 3000 Start Up	5		
Navigation	5		
Display Icons	6		
Select Functions	7		
Start Delivery	7		
Show Last	8		
Begin or End Shift	8		
View Inventory	8		
Duplicate Shift Ticket	9		
Re-Print Tickets	9		
System Menu	9		
<b>Reports</b>	10		
Operating Parameters	10		
Show Prover Status	10		
Last Prover Ticket	10		
Prover Ticket	10		
Meter Info	10		
Version Info	10		
Memory Status	10		
Network Status	10		
Checksums	10		
Preview Prover Ticket	10		
Preview Error Log	10		
Print Error Log	10		
Config Parameters	10		
Tickets	10		
Last Delivery Ticket	10		
Find Ticket	10		
<b>System Settings</b>	11		
Language	11		
Display Settings	11		
Printer Settings	12		
Enable/Disable Printer	12		
Select Printer	12		
Printer Host	13		
Regional Settings	13		
Time/Date	13		
Delivery Settings	13		
QR Receipt Settings	13		
Preset Settings	13		
Multiple Deliveries	13		
Customer ID Options	14		
Selectable Database	14		
Display Precision	14		
Pause Options	14		
Auxiliary Devices	15		
External Display	15		
Air Elimination	15		
Pulser Output	15		
RFID Reader	15		
Analog Input	16		
Level Meters	16		
Differential Pressure Sensors	17		
Water Sensor	17		
Density Sensor	17		
Interlock	17		
Lamp Indicator	18		
Connectivity	18		
Configure Ticket Headers/Footers	19		
Misc. Settings	19		
Level 1 Password	19		
Level 2 Password	19		
Access Key	19		
System Mode	19		
User Database Update	19		
Startup Logo	19		
Hardware Tests	19		
<b>Weights &amp; Measure (W&amp;M) Settings</b>	20		
Products	20		
Recalibrate Product	20		
Modify Parameters	20		
Product Name	20		
Compensation Tables	20		
Linear Table Parameters	21		
API Table Parameters	21		
Mass Density	22		
Pump Control & Timing	22		
Speed Control 1	22		
Speed Control 2	22		
Valve Type	22		
S1 - S2 Delay	22		
Max Flowrate	22		
Flow Rate Limits	23		
S2 Flow	23		
Pulser Type	23		
Product Units	23		
Hose Volume	24		
Max Pulse Error	24		
Additive Injector	24		
External Piston Pressure	25		
Begin Recalibration	26		
Full Calibration	26		
Add Point	27		
Perform Test Run	27		
Edit Product Calibration	27		
Edit Calibration Meter Factors	28		
Add New Product	29		
Remove Product	29		
Hose Charge	29		
Accounting	29		
Next Ticket Number	29		
Require Ticket Print	29		
Configure Tickets	29		
Delivery Screens	31		
System Metrics	32		
Temp Probe	33		
Meter Information	33		
Prover Ticket	33		
Ticket Cleanup	33		
Reset Totalizers	33		
Zero-Flow Timeout	34		
Miscellaneous W&M	34		
Transfer Key	34		
Pulser Tracker	34		
Test Pulser	34		
Additive Injector	34		
Config Settings	34		
Enable Remote Config	34		
W&M Test Menus	35		
System Cloning	35		
<b>Product Settings</b>	35		
Inventory	35		
View Inventory	35		
Update Inventory	35		
Assign Inventory	35		
Add Inventory	35		
Remove Inventory	35		
Inventory Settings	35		
Product Prices	36		
Activate Product	37		
Deactivate Product	37		
Product Parameters	37		
Product Density	37		
Preset Parameters	37		
Dwell Volume	38		
S1 Close Volume	38		
S2 Check Point	38		
S2 Close Volume	38		
Flow Parameters	38		
Air Eliminator Hold	38		
Startup Volume	38		
Preview Product Parameters	38		
Print Product Parameters	38		
Auxiliary Settings	39		
Additive Injector	39		
Differential Pressure Sensor	39		
Water Sensor	39		
Density Sensor	40		
Product Lists	40		
<b>Users ID Management</b>	41		
Number of Records	41		
Add/Edit ID	41		
Remove ID	41		
<b>Advanced Functions</b>	41		
Lock the System	41		
System Shutdown	41		
System Update	42		
Service Menu	42		
System Logs	42		
Export Tickets	42		
Export Ticket Configuration	42		
Daisy Chain	44		
Inventory How To Setup	46		
Temperature Probe Calibration	47		
Trouble Shooting	48		
Display Icons	49		
Hardware/Software	49		
System Settings	51		
W&M Settings	52		
Product Settings	54		
Modem	55		
TCS 3000 Register Parts Breakdown (Generation 2)	56		
Warranty	57		

---

## Receipt & Inspection

Upon receipt of register shipment, be sure to inspect the packaging and the register assembly for any damage before signing the receipt of the shipment. Notify the delivery company about possible damage and refuse receipt of the shipment.

Registers are individually boxed and are protected with static resistant packing material. Each package is identified with the register assembly part number, description, serial number. Verify the register model is the correct model, size, and configuration as ordered. Contact your distributor if there is any discrepancy or question.

Register assemblies should be handled with appropriate methods for the size and weight involved. Appropriate clothing and shoes need to be utilized. Transport the register package to the installation site with appropriate transportation methods, careful not to damage the register.

Be careful of any loose or protruding staples from the packaging, as they can be very sharp and may potentially cause injury.

If foam has been used to protect register, carefully remove top foam layer before attempting to remove register assembly from box. Foam packaging maybe formed around the register assembly making it difficult to remove. Do not lift the register assembly by wires or anything other than the metal body of the register. Do not insert objects or cables into the register unless stated. Removing register assembly from packaging without adhering these warnings may cause serious injury to you and/or the register.

Appropriate precautions should be taken regarding any personal, environmental and material compatibility with the end use system.

## Notice

Total Control Systems (TCS) shall not be liable for technical or editorial errors in this manual or omissions from this manual. TCS makes no warranties, express or implied, including the implied warranties of merchantability and fitness for a particular purpose with respect to this manual and, in no event, shall TCS be liable for special or consequential damages including, but not limited to, loss of production, loss of profits, etc.

The contents of this publication are presented for informational purposes only, and while every effort has been made to ensure their accuracy, they are not to be construed as warranties or guarantees, expressed or implied, regarding the products or services described herein or their use or applicability. We reserve the right to modify or improve the designs or specifications of such products at any time.

TCS does not assume responsibility for the selection, use or maintenance of any product. Responsibility for proper selection, use and maintenance of any TCS product remains solely with the purchaser and end-user.

***All rights reserved. No part of this work may be reproduced or copied in any form or by any means – graphic, electronic or mechanical – without first receiving the written permission of Total Control Systems, Fort Wayne, Indiana USA.***

# Introduction

The TCS 3000 register is a fully integrated custody transfer flow computer that will control a majority of the vehicle delivery operations. The Open Software Architecture provides the option of a simple “*Pump & Print*” delivery or a custom measurement solution. The TCS 3000 features a 7”x 3.5” full color VGA display screen, multiple delivery screens and a flexible mounting with backlit alpha-numeric keypad for the user interface. Software features offer complete flexibility of delivery screen information and view, preset, price/tax, ticket format and password protection. Available in flexible mounting configurations of 75 or 90 degree displays for meter mounting, and a remote mounting.

As a flow computer with open software architecture, there will always be a need to add features to the register as the industry applications evolve. Therefore please be reminded to contact the factory for periodic updates.

Optional GPS, Bluetooth, Wi-Fi and Cellular capability enables the TCS 3000 to improve your product security and ease access to your delivery data to reduce your operation costs. Many additional features are available (multiple product delivery, additive injection, density/temperature correction, multiple valve & pump control, etc.) to enhance your measurement solution.

TCS 3000 - This manual will help guide you with the setup confirmation and calibration of the register. Additional information will be provided for wiring instruction and auxiliary devices to integrate into the register.

# System Specifications



TCS 3000



TCS 3000ex

Supply Voltage	10-30 Vdc	10-30 Vdc
Current	1.4A	3.3A
Maximum Hertz	5000 Hz	5000 Hz
Relay Outputs	Passive Solid State	Open Collector
Calibration Seal	Hall Effect Switch	Hall Effect Switch
Aluminum Enclosure	IP 66 / NEMA 4	IP 66 / NEMA 4
Hazardous Rating	UL/cUL Class 1, Division2, Group C & D	UL/cUL Class 1, Division1, Group C & D ATEX and IECEx Class 1 Zone 1, Group IIB, T4
Temperature	-40F to 158F (-40C to 70C)	-40F to 140F (-40C to 60C)
Connection	Ten (10) 1/2” NPT or M20 Threaded Ports	Ten (10) 1/2” NPT or M20 Threaded Ports

### Backlit LED Keypad

### COMMUNICATION

Three (3) RS 485 output, 2-wire half duplex, custom protocol; 9600 baud, 8 bit, no parity, 1 stop bit

Two (2) RS 232 output, 9600 baud; 8 bit, no parity, 1 stop bit

The USB 0, USB 1 and USB 3.0 ports are for maintenance only. To access these USB ports, power to the unit is to be disconnected or the area known to be free of ignitable gas or equivalent.

## WARNINGS:

WARNING– EXPLOSION HAZARD– DO NOT DISCONNECT EQUIPMENT WHILE THE CIRCUIT IS LIVE OR UNLESS THE AREA IS KNOWN TO BE FREE OF IGNITABLE CONCENTRATIONS

WARNING– EXPLOSION HAZARD– SUBSTITUTION OF ANY COMPONENT MAY IMPAIR SUITABILITY FOR CLASS 1, DIVISION 2.

## TCS 3000 Register Start Up:

### Caution

Before Placing this product into service, make sure that the register has been properly calibrated and setup for the type of fluid being measured. This includes calibration factor, compensation type, compensation parameter, product type, valve settings, no flow timeout and others. Refer to the operation manual supplied with the register for instructions. Failure to properly calibrate and setup the register can result in unexpected operation, inaccurate measurements and damage to equipment or property.

**SHIFT + MODE (SAME TIME) = SYSTEM MENU**



## Navigation Keyboard Functions



Arrow Keys

- |                 |   |
|-----------------|---|
| Power Light     | Allows you to see that there is power to the electronic register. |
| Start/Enter Key | Allows you to enter register functions and start deliveries.      |
| Stop/Cancel Key | Allows you to stop a delivery and cancel an operation.            |
| Arrow Keys      | Allow you to move to different fields on the Register.            |

# Navigation Keyboard Functions (Continued)

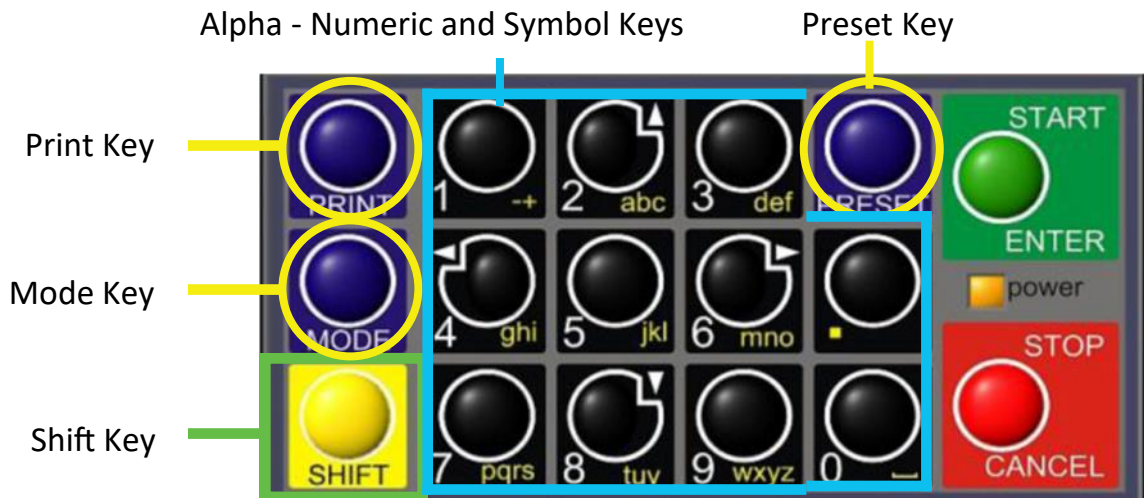

- Preset Key Allows you to PRESET the Price and Tax as well as Gallons into the Register.
- Alpha - Numeric Keys Allow you to enter different prices, products, etc. into the Register.
- PERIOD Hold Shift key while pressing Period key for symbols: ., %, @, &, (, ), /, #, - and \_.
- Mode Key MODE allows you to select different screens on the Register.
- Print Key Allows you to print. You can print the delivery with or without selecting the STOP key.
- Shift Key Allows you to select the Alpha Keys on the Alpha/Numeric Keys. Selecting Shift allows you to use anything on the Key Pad in yellow.
- Shift & Mode Allows you to get into the main Menu screen.

## Display Icons

ICON	DESCRIPTION
	Printer with no ticket.
	No printer connection
	Printer ready with Ticket
	Pump Off / Valve(s) Closed
	Pump On / Valve(s) Open
	Multiple Tank Delivery
	System Settings
	Weights & Measures
<b>AIR</b>	Air/Vapor Present
	Density Error
	Water Present
	WIFI / Cellular Connection
	WIFI Access Point Connection
	Ethernet Connection

## SELECT FUNCTION MENU

<b>Start Delivery</b>	Begins delivery transaction.
<b>Show Last Delivery</b>	Shows the last delivery on the TCS 3000 screen.
<b>Begin or End Shift</b>	Beginning Shift will take a record of Delivery information at the start through the end of the user shift. Shows the inventory in the tank.
<b>View Inventory</b>	Shows the inventory in the tank.
<b>Duplicate Shift Ticket</b>	Duplicate Shift Ticket will print a duplicate of the Begin or End Shift.
<b>Re-Print Tickets</b>	Will reprint past delivery transactions
Non-Printed Delivery	Prints the last transactions that have not printed.
Already Printed Delivery	Reprints the last ### of transactions already printed
Shift Tickets	Reprints the last ### of shift tickets.
<b>System Menu</b>	Setup and Configuration MENU'S for TCS 3000
Reports	Calibration Log / Identification, Software Version and Reporting
System Settings	Configuration of System Parameters, Printer and Auxiliary Devices
W&M Settings	Product/System Setup and Calibration
Product Settings	Product Activation, Price Settings, Device Time Settings & Auxiliary Settings
Users ID Management	Customer ID database to manage Asset, Employee, Customer validation and delivery authorization
Advanced Functions	System Software Update

## Start Delivery

- 1) **START DELIVERY.** Press START to begin delivery transaction. This will reset the display to Zero to begin your delivery.
- 2) If a Preset or Customer ID Field is Enabled, the delivery process will begin with prompts requesting data input. See Page 13 for Preset Settings or Page 14 for Customer ID Field to Enable/Disable.
- 3) If a Multiple Tank Delivery is Enabled, the Operating Driver must Hold the SHIFT key down while pressing the START key. When the Multiple Tank Delivery begins, a multiple tank icon will be displayed during delivery. See Page 13 for Multiple Tank Delivery to Enable/Disable.
- 4) Finish the delivery. Press STOP once to finish delivery. Or, press STOP once to PAUSE and twice to STOP, if Delivery Pause is enabled. If the Printer is Enabled, the ticket will be printed automatically. If the printer is not Enabled, it will be stored in memory to be retrieved at a later date.



## Show Last

**Show Last** Press START/ENTER to see the last delivery transaction

## Begin Shift/End Shift

The Shift function records the Time/Date, Meter Identification and the Delivery Data from the beginning of the shift to the end of the shift. NOTE: This function is only accurate as the driver operators that utilize this feature.

**Begin Shift** Press and hold the SHIFT key, then press the MODE key.  
**End Shift** Press and hold the SHIFT key, then press the MODE key.

After or before each Shift, the display will read Saving and Printing BEGIN or END Shift Ticket.

### Sample Begin and End Shift Tickets

```

Total Controls Systems
2515 Charleston Place
Fort Wayne, IN 46808
Voice (800) 348-4753
Fax (260) 484-9230
=====
                BEGIN SHIFT TICKET
=====
Driver   : Kelly, Bob
Start   : 09/29/10 20:54:10
Unit    :      3
First Ticket :      5
Gross Start Total : 8.0
-----
Starting Inventory :
Fuel Oil           2000.0
Gasoline           2000.0
Diesel             654.9
=====
Driver Signature
    
```

```

Total Controls Systems
2515 Charleston Place
Fort Wayne, IN 46808
Voice (800) 348-4753
Fax (260) 484-9230
=====
                END SHIFT TICKET
=====
Driver   : Kelly, Bob
Start   : 09/29/10 20:54:10
End     : 09/29/10 20:54:32
Unit    :      3
Deliveries :      0
-----
Total Sales : 0.00
-----
Gross Start Total : 8.0
Gross End Total   : 8.0
Gross Shift Del   : 0.0
-----
Ending Inventory :
Fuel Oil           2000.0
Gasoline           2000.0
Diesel             654.9
=====
Driver Signature
    
```

## View Inventory

View Inventory allows you to select and view the inventory of product in the tank.

**INVENTORY DISPLAY** Displays the inventory and tank size.

**SELECT INVENTORY** Allows you to use the arrow keys to select the product in order to view the Inventory Details.

**PRINT INVENTORY REPORT** Generates a ticket of the Inventory Report

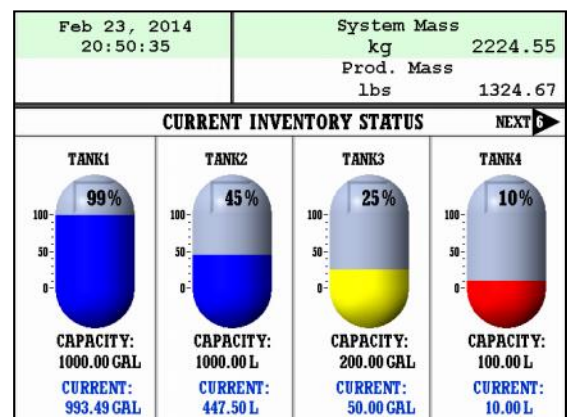

---

## Duplicate Shift Ticket

To print a Duplicate Shift Ticket, navigate down to select the function and press ENTER.

## Re-Print Tickets

To locate and reprint a past delivery ticket, navigate down to select the function and press ENTER

<b>Non-Printed Delivery</b>	Will ask how many of the last sequential tickets (that have NOT printed) do you wish to print. Enter quantity and press ENTER.
<b>Already Printed Delivery</b>	Will ask how many of the last sequential tickets do you wish to re-print. Enter quantity and press ENTER.
<b>Non-Printed Inventory</b>	Will ask how many of the last sequential inventory tickets (that have NOT printed) you wish to print. Enter quantity and press ENTER.
<b>Printed Inventory</b>	Will ask how many of the last sequential inventory tickets you wish to re-print. Enter quantity and press ENTER.
<b>Shift Tickets</b>	Will ask how many of the last sequential tickets do you wish to re-print. Enter quantity and press ENTER.

## System Menu (Quick Guide)

### Reports

<b>Operation Parameters</b>	View and print calibration, meter information and software
<b>Show Prover Status</b>	View existing voltages, temperatures and runtimes
<b>Last Prover Ticket</b>	Weights & Measures access, calibration and configuration log
<b>Meter Info</b>	Print the last calibration proving ticket
<b>Version Info</b>	Meter identification
<b>Memory Status</b>	Operating Firmware and Software
<b>Network Status</b>	View stored delivery, inventory, calibration and transferred (TCS HUB) tickets
<b>Checksums</b>	View System Network, WIFI, Ethernet, Broadcast or Remote Interface status
<b>Preview Prover Ticket</b>	View checksums from software, firmware and operating system
<b>Preview Error Log</b>	View Prover Ticket without a printer
<b>Print Error Log</b>	View error logs from register without a printer
<b>Config Parameters</b>	Print error logs from register
<b>Tickets</b>	View system configuration parameters
	View Last Delivery Ticket or search for old ticket

### System Settings

<b>Language</b>	Configuration of system functions
<b>Display Settings</b>	Choose the system language from English, Spanish, Portuguese or French
<b>Printer Settings</b>	Configure display screens and fields
<b>Regional Settings</b>	Select printer, host ,remote or none
<b>Delivery Settings</b>	Date and Time settings
<b>Auxiliary Devices</b>	Configure delivery functions like tickets, presets, ID fields, etc.
<b>Connectivity</b>	Select and configure auxiliary devices and pulse output
<b>Configure Tickets</b>	Configure register and printer addresses for network data sharing
<b>Misc. Settings</b>	Configure ticket headings and footers
	Password and Database settings

### W&M Settings

<b>Products</b>	Weights & Measures product setup and calibration
<b>Accounting</b>	Product settings and calibration
<b>Delivery Screens</b>	Set ticket number, configure delivery tickets
<b>System Metrics</b>	Configure delivery screen fields for display
<b>Temp Probe</b>	Unit of measure precision
<b>Meter Information</b>	Temperature probe calibration
<b>Prover Ticket</b>	Register, Meter and Truck Identification
<b>Tickets Cleanup</b>	Print calibration proving ticket
<b>Reset Totalizers</b>	Allows you to delete the oldest 500 printed tickets over 5000 transactions
<b>Zero Flow Timeout</b>	Reset system and product totalizers
<b>Miscellaneous W&amp;M</b>	Ends delivery with preset time from the last metered pulse input
	Air Eliminator, Product Transfer, Pulser Tracking outside of delivery, Test Menus, System Cloning

### Product Settings

<b>Inventory</b>	Product settings within Shifts for inventory, preset and auxiliary settings
<b>Product Prices</b>	Create or remove tank inventories; as well as assigning products to these tanks
<b>Activate Product</b>	Product pricing and taxation
<b>Deactivate Product</b>	Activating onboard products within Shifts
<b>Product Parameters</b>	Deactivating onboard products outside of Shifts
<b>Auxiliary Settings</b>	Product preset and auxiliary device timing
<b>Product Lists</b>	Auxiliary device configuration for a Additive Injector, Pressure Sensor, Water, Density, etc
	Listing of active, inactive and uncalibrated products

### Users ID Management

<b>USER_DB (1-6)</b>	User database management for PIN authorization or RFID asset management
----------------------	---

### Advanced Functions

<b>Lock The System</b>	Administrative Configuration
<b>System Shutdown</b>	Lock the system down from use, requires remote computer for operation
<b>System Update</b>	Rebooting of system
<b>Service Menu</b>	Software update
<b>System Logs</b>	Hardware Tests
<b>Export Tickets</b>	Download generated system logs to attached USB Drive
<b>Export Ticket Config</b>	Download generated tickets from system to attached USB Drive
	Download ticket configuration to copy to other registers via USB Drive

# Reports

## OPERATION PARAMETERS

Operation Parameters allows you to view the live Battery and 5V Supply Voltage to internal components, as well as Display, Main Board and RTD temperatures. The Runtime is the accumulated time of the register operation from the factory.

## SHOW PROVER STATUS

Show Prover Status allows you to view the last date and time of the last calibration.

## LAST PROVER TICKET

Last Prover Ticket allows you to print the prover information from the register.

## METER INFO

Meter Info allows you to view the Meter Data, such as The Truck ID, Register ID, Meter Make, Meter Model, Meter Version, and the Meter Serial Number. Information must be input within the Weights & Measures menu.  
+++ Required for Calibration Prover Ticket +++

## VERSION INFO

Version Info allows you to view the Version of Software and Firmware running on the TCS 3000.

## MEMORY STATUS

Memory Status allows you to view the number and type of tickets printed by the TCS3000. The Transferred and Non-Transferred deliveries show whether the delivery information has been seen and transferred to third party software accounting POS programs.

## NETWORK STATUS

Sys Net Overview	Display the current IP address and the network connection for any type.
WIFI Status	Display the current IP address and the network connection for WIFI.
Ethernet Config Report	Display the current IP address and the network connection for Ethernet.
TCP Display Broadcast	Display port, mode and clients.
Remote Interface	Configuration settings (RS232 or TCP) and port.

## CHECKSUMS

Selecting Check Sums allows you to check the TCS 3000 software for errors.

Software Checksum

Firmware Checksum

OS Checksum

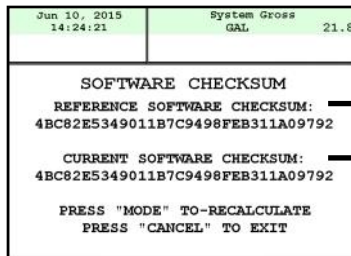

The Reference and Value must match. If the values do not match, select MODE to recalculate the value.

## PREVIEW PROVER TICKET

Preview Prover Ticket will allow you to scroll page by page through the calibration prover ticket.

## PREVIEW ERROR LOG

Preview Error Log will allow you to scroll through the error log of the TCS 3000 computer.

## PRINT ERROR LOG

Print Error Log allows you to print the error log of the TCS 3000 computer.

## CONFIG PARAMETERS

Preview Parameters	Scroll through the system configuration parameters.
Print Parameters	Print the system configuration parameters.

## TICKETS

Last Delivery Ticket	Review the most recently generated delivery ticket.
Find Ticket	Allows you to search through generated tickets on the 3000. (Continue to next page)

Yesterday  
Date

Search for all delivery tickets from yesterday.  
Allows you to select a date for the ticket search. The format is shown on top of the screen. 19.01.12 will find tickets for the day of 1/12/2019.

Date Range

Allows you to select a date range for the ticket search. The format is shown on top of the screen. 19.01.12-19.01.18 will find tickets for the range of 1/12/19 to 1/18/19.

## System Settings

### LANGUAGE

Choose the language that you want the system and product settings to be displayed.

- ENGLISH
- FRENCH (Not available)
- SPANISH (printed ticket only)
- PORTUGUESE (printed ticket only)

### DISPLAY SETTINGS

#### Default Screen

Select the Type of Screen you would like the TCS 3000 to default to.

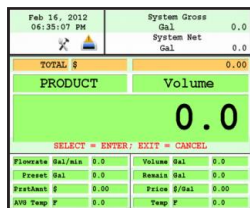

TYPE 1

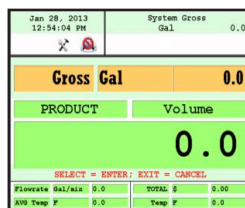

TYPE 2

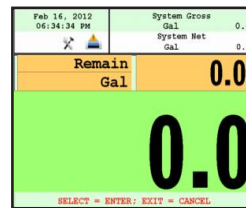

TYPE 3

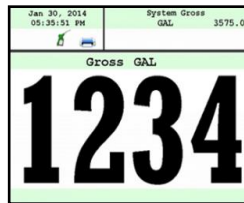

TYPE 4

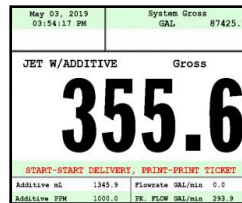

TYPE 5

\* TYPE 4 Only displays delivered volume.

#### Screensaver

- Disable
- Select
- Set Timeout
- Preview

#### Available only with the "New Look" Display Settings.

Disables the Screensaver  
Choose from NONE, Save a Life and the TCS logo  
The display timeout setting in Minutes before the screensaver appears  
Will show the screensaver logo on display screen. Press Enter to Exit.

#### Calibration Screen

- Temperature
- Flowrate
- Empty

Calibration screen will show volume/mass and Temperature  
Calibration screen will show volume/mass and Flowrate  
Calibration screen will show volume/mass and nothing else

#### Brightness

Brightness allows you to set the brightness of the display screen from 100 to 30 percent (brightest to dimmest) settings.

#### Net Totalizer

- Always
- Auto

- Never
- Mass

Net Totalizer allows you to set whether the Net Totalizer is visible on the display screen.

Net Totalizer is always visible  
Net Totalizer is visible only when a product has Automatic Temperature Correction (ATC) enabled on a Product  
Net Totalizer is never visible  
Mass totalizer is always visible

#### Gross Totalizer

Gross Totalizer allows you to set whether the Gross or Volume Totalizer is visible on the display screen.

- Volume Totalizer
- Mass Totalizer

Volume Totalizer is always visible  
Mass Totalizer is always visible

## Display Size

5.7 INCH  
7 INCH

Reformat display to 5.7 inch size  
Reformat display to 7 inch size

## Set Display Style

Allows you to change display background and text colors on the 7" display size.

**New Look** To change the background and text colors, a restart will be required. Press Shift+ Mode and DISPLAY COLORS will appear in the Display Settings upon restart.

**Classic** The Classic display colors with a white background and black text.

## Display Colors

**Load/Edit Color Theme** Night, Light, Blue are currently available

**Set Color A** Select color for contrasting background lines. Press Enter to preview and Mode to apply.

**Set Color B** Select background color. Press Enter to preview and Mode to apply.

**Set Text Color** Select color for all text. Press Enter to preview and Mode to apply.

**Set Sys Msg Color** Select the System Message text color. Press Enter to preview and Mode to apply.

**Set Tempcomp. Color** Select the Temperature Compensation text color. Press Enter to preview and Mode to apply.

**Reset to TCS Original** Select reset to TCS original to bring you back to the Classic white background and black text display colors.

NOTE: Display Colors will not appear until you enter Set Display and select New Look.

Example 1

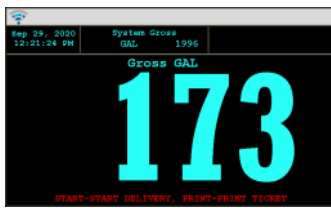

Example 2

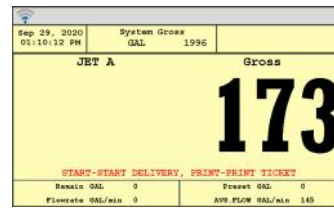

## Day/Night Display

**Enable Day/Night** Allows the display to be changed between the programmed Day and Night displays.  
**Set Current to "DAY"** When you have configured your display for Day settings, press Current to Day to set this display as your Day theme.

**Set Current to "NIGHT"** When you have configured your display color for Night settings, press Current to Night to set the display as your Night theme.

**Config Day/Night Timer** After the Day and Night themes have been set, press Configuration Day/Night Timer to set the SUNRISE and then SUNSET time (HH.MM) and Enter.

NOTE: you will need to cycle power for the register Day/Night Timer to function.

## PRINTER SETTINGS

### Enable/Disable Printer

**Enable** Allows the printer to operate. Highlight Enable and select ENTER. When the printer is Enabled, a printer icon will appear in the top left screen position.

**Disable** Will not allow the printer to operate. Highlight Disable and select ENTER. When the printer is Disabled, the little printer will disappear in the top left screen position.

### Select Printer

**None** No printer is to be used, will remove the communication for printing.

**Remote** Client Registers must select Remote to allow you to use a printer remotely when connected to the register through a daisy chain RS485 serial communication.

**Epson TMU 220/295** Epson slip or roll printer driver installed

**Citizen CMP30** Citizen printer driver installed

**DDP-350** Stimare printer driver installed

**Blaster** Blaster printer driver installed

**Blaster\_DLXI** Blaster printer driver installed

**Blaster\_CR** Blaster printer driver installed

**Printek\_FP NET** Printek WIFI wireless driver installed. Printer IP address will be entered here.

Once your printer has been selected, you will then be prompted with two questions:

Auto Eject                      Enable or Disable the delivery ticket if a slip printer is being used. Select Disabled for any roll printer.

Print Confirmation            Enable or Disable a confirmation after each delivery ticket. Select Enabled for WIFI printers.

**Printer Host**

Printer Host is used when you plan to daisy chain multiple TCS 3000 registers together for a single printer. Host is the primary meter and the Clients are all registers following the Host. Client registers must select the Remote printer.

Enable/Disable Host        To Enable or Disable the Printer Host, highlight Enable or Disable and select ENTER  
 - Enable will allow you to use Printer Host  
 - Disable will not allow you to use Printer Host

Clients Address Range    Use the keypad to define the starting and ending address range of registers on the daisy chain (See pages 43-44 for instructions on how to daisy chain).

**REGIONAL SETTINGS**

**Date & Time**

Date Format                    MMMM DD, yyyy  
                                      MM/dd/yyyy  
                                      yy/MM/dd  
                                      dd/mm/yyyy  
                                      dd/mm/yy

Time Format                    24 Hour Clock  
                                      12 Hour Clock AM/PM

Set Date                      Year — Format YYYY  
                                      Month — Select Month  
                                      Date — Select Date

Set Time                      Format time: Hours.Minutes.Seconds (HH.MM.SS)  
                                      NOTE: Hours - 24 hr. clock and a period must be used as your divider

**Decimal Symbol**        Select a '.' period or a ',' comma and press ENTER

**DELIVERY SETTINGS**

**QR Receipt Settings**

*Enable QR Receipt*            Enable or Disable QR Code

*Configure QR Receipt*        Change how the QR Code page will display on the 3000.

*Edit QR Receipt*                Edit the delivery information that displays on the QR Code page

*QR Screen Title*                Change the title that shows at the top of the QR code page

*Preview QR Receipt*            Preview the current setup of the QR Code page

*Restore Default Receipt*        Reset QR Code page to default setup

**Preset Settings**

Enable Preset            Utilizing the preset will request a preset amount before a delivery begins. After selection, press ENTER to complete setting.

*Enable Preset*                    Enable or disable preset

*Preset By Price*                Enable or disable preset by Price

*Gross Preset*                    Enable or disable preset in GROSS VOLUME

*Net Preset*                        Enable or disable preset in NET CORRECTED VOLUME

*Retain Preset*                  Enable or disable preset for repeat BATCH presets

*Preset Top Off*                 Enable for preset batch and Pause. Press START to continue delivery  
 NOTE: PAUSE OPTION must be enabled for this to work (see page 14)

NOTE: Each Preset Setting requires configuration under Product Settings for S1 and S2 operation. (See page 37 for instructions on how to configure Preset valve closure).

---

## Multiple Deliveries

Allows for the user to fill multiple tanks on one (1) single ticket transaction. Simply press and hold the SHIFT key down while pressing the START key to begin the multiple deliveries.

If preset is enabled, each tank delivery will prompt the preset amount.

If using the following Customer ID option, you can setup each delivery for identification fields 1 and 2 at the beginning of the delivery record, and customer identification fields 3 through 6 to identify the multiple Assets or Tanks within the delivery transaction.

## CUSTOMER ID OPTIONS

The Customer ID Option will provide four (4) selectable database fields and six (6) customer identification fields for the user to input prior to the delivery. The Customer Identification is normally used for Tank, Truck, Airplane Tail No., Locomotive, Driver, Customer, etc.

**Selectable Database** These four (4) selectable database questions will prompt the fueling operator to chose from the database list of items prior to the delivery.

### Selectable Database (1-4)

Set DB Title Enter database name

Enable/Disable Enable or disable the selectable database feature. Selectable database prompts will show prior to the Customer ID (1-6) user defined data entry.

View/Edit Add, Edit or Remove selectable selections.

Update Databases Selectable database 1-4 are updated with one file TCS formatted database update to your register.

*\*\*This will require a FAT 32 formatted USB drive\*\**

Overwrite Using a USB thumb drive, you can overwrite an existing database file with a new database.

Add Using a USB thumb drive, you can add selectable database options to existing databases.

**Customer ID# (1-6)** Customer ID fields are user defined fields or databases that can be used to validate and authorized a delivery or provide more detail for the delivery record.

Customer ID# Text field programmable for identification

Request ID# Field prompts user to enter an ID

Enforce ID# Field requires user to enter an ID in order to operate the system

Validate ID# Field validates the ID to ensure the ID is in the database, if invalid the system will be inoperable. This option requires the use of the USERS ID MANAGEMENT located on page 40. Enabling this feature without a User's ID database record will not be able to perform a delivery.

## Display Precision

The unit precision can be displayed as a whole, tenth, hundredth or thousands measurement. After selection, press ENTER to complete setting.

1	Whole Unit
1.1	Tenth Unit
1.11	Hundredth Unit
1.111	Thousands Unit

## Pause Options

Pause controls how pump control is used.

Allow Pause Allow Pause will Pause the delivery with the Pump engaged

Pause Pump Pause Pump will stop the pump during a Paused delivery

*++ Allow Pause must be enabled for PRESET TOP-OFF & WATER ALERT to work properly ++*

---

## AUXILIARY DEVICES

### External Display

The External Display setting is for the specific manufacturers of large LED displays. This setting is for serial communication to an ancillary display that will read the same data that is displayed on the TCS 3000 register.

Enable/Disable	Enable or disable and press ENTER
Configure	Select Type: Total Control Systems, Red Lion LD, Omega & Tekinno displays are currently the only external displays supported today Address: Display Address from 1 to 99 and press ENTER Select Position: Select location for information to be on LEFT or RIGHT. Display Data Choose the information to display on External Display and press ENTER. Options are Delivery Gross, Delivery Net, Delivery Volume, Delivery Total (Currency), Flow Rate and Mass
Test	This is a test sequence of numbers to exhibit on external display

### Pulse Output

The solid state pulse frequency transmission of a scalable pulse factor  
*++ May require a 1K ohm pull down resistor to bring pulse to ground (0Vdc) ++*

Enable/Disable	Enable or disable operation
Configure	Sets the DEFAULT for pulse transmission output data  Delivery Total (Currency)  Gross Volume 1        (1 pulse per unit) 1.1     (10 pulses per unit) 1.11    (100 pulses per unit) 1.111   (1000 pulses per unit)  Net/Gross Auto Detect Volume 1        (1 pulse per unit) 1.1     (10 pulses per unit) 1.11    (100 pulses per unit) 1.111   (1000 pulses per unit)  Pulse Repeater repeats the incoming pulse value
Startup Reset	Enable or disable and press ENTER

### RFID Reader

Radio Frequency Identification (RFID) is for fixed location or fleet refueling.

*++ requires the a database for this option to be used , see page 40 for USERS ID MANAGEMENT ++*

External ThingMagic	External is used for remote mobile readers ThingMagic is for fixed reader locations
---------------------	--

---

## ANALOG INPUT

Analog Input is for the 4-20 mA or voltage expansion communication boards used with the Tank Level Gauges, Differential Pressure, Water and Density sensors.

*++ Must complete sensor settings within Product Settings on Pages 35 – 40 ++*

- None** Nothing is selected.
- X1 Channel** Single channel only allows you to use 1 device with the TCS 3000, chosen from Level, Differential Pressure, Water or Density.  
- Must choose the input:  
- Voltage (5 Vdc Capacity)  
- Current (4 - 20 mA)
- X3 Universal** Three channel allows you to use 3 devices with the TCS 3000, chosen from Level, Differential Pressure, Water and Density.  
- Each channel input must be designated between Voltage and Current:  
- Voltage (5 Vdc Capacity)  
- Current (4 - 20 mA)  
- Reset to Default will change each channel back to Current and all values returned to zero (0).
- NOTE: The X1 or X3 channel analog communication board are mounted within the TCS 3000 register.
- X8 Channel** Eight channel allows you to use 8 devices with the TCS 3000 for Level, Pressure and Water.  
NOTE: Externally mounted from the TCS 3000 register in a NEMA 4X enclosure.  
- Level Meters (1 - 6)  
- Voltage (5 Vdc Capacity)  
- Current (4 - 20 mA)  
- Pressure and Water (7 - 8)  
- Voltage (5 Vdc Capacity)  
- Current (4 - 20 mA)

## LEVEL METERS

Select Level Meter - number available depends on the Analog Input board that is selected.

<b>Measurement Unit</b>	Chose from Gal, L, UKG, daL, dL, mL, m3, cm3, bbl, floz, ft3 or in3.	
<b>Linearization Type</b>	External (0-100%)	Linear capacity percentage to volume level.
	Quasi Linear	Linear capacity from the minimum to highest level with curves.
	Polynomial	Nonlinear capacity to volume level.

### Calibration

- View/Edit** Allows you to enter the percentage or height of volume in the tank. You can add as many points as needed, but a minimum and maximum level must be entered.
- Select Existing** Choose from existing Almac or Mid-States single compartment tank strapping charts.
- New Calibration** Automatically senses the tank level, READ the instructions on the TCS 3000 Screen as it guides you through the calibration. Display will show tank level in percentages.  
1) Press Start to begin with the level adjustment by adjusting the level up or down.  
2) Press MODE to store the level and enter the volume.  
3) Press Stop to finish each point.  
4) Repeat as many times as necessary. No point can be less then 0.11%.  
5) Make sure to calibrate as close to Empty (0%) and Full (100%) levels.  
6) When finished, press Stop and then MODE to complete the tank chart.
- Preview Existing** to view the existing strapping charts entered on the TCS 3000 register.  
1) Press Enter to view and select a chart for the Level Channel.  
2) Select chart to delete by pressing Shift + Stop at the same time.

---

## DP, H2O & DNS (Differential Pressure, Water & Density)

Select the Sensor Type for the **X1** channel board between Differential Pressure, Water or Density); or assign the **X3** channel (DP1, DP2 and DP3) to the Sensor Type (Differential Pressure, Water or Density).

### Differential Pressure Sensor

Allows you to program the maximum and minimum pressure of the vessel. If the pressure is too low or too high the systems will shutdown. The TCS 790947 and 790948 pressure differential pressure settings should be 0 PSI at 4mA Minimum and 100 PSI at 20mA for Maximum.

- View/Edit
- 1) Minimum Pressure Input
  - 2) Minimum Output Current mA or Voltage Entry
  - 3) Maximum Pressure Input
  - 4) Maximum Output Current mA or Voltage Entry

NOTE: Settings will be based on whether Current (mA) or Voltage was selected under Analog Input Settings

Unit Choose the Unite of Measure: PSI, BAR, Pa, kPa, mPa, kg/cm2  
Precision System Precision or 1-6 digits from whole number

### Water Sensor

Allows you to program the maximum and minimum capacity of the Water sensor to read correctly. The Faudi Electronic Water Sensor should be 0 PPM at 4 mA Minimum and 50 PPM at 20mA for Maximum .

- View/Edit
- 1) Minimum Concentration Water PPM Input
  - 2) Minimum Output Current mA Entry
  - 3) Maximum Concentration Water PPM Input
  - 4) Maximum Output Current mA Entry

NOTE: Settings will be Current (mA) Only

Unit Choose the Unit of Measure: PPM  
Precision System Precision or 1-6 digits from whole number

### Density Sensor

Allows you to program the maximum and minimum capacity of the Density sensor for correct measurement. The TCS 790945 and 790946 density sensor settings should be 400 kg/m3 at 4mA for Minimum and 1500 kg/m3 at 20 mA for Maximum.

- View/Edit
- 1) Minimum Density per Unit of Measure Input
  - 2) Minimum Output Current mA Entry
  - 3) Maximum Density per Unit of Measure Input
  - 4) Maximum Output Current mA Entry

NOTE: Settings will be Current (mA) Only

Unit Choose the Unit of Measure: lbs/GAL, kg/M3, kg/L, lbs/UKG, lbs/ft3, lbs/in3, lbs/floz, oz/floz  
Precision System Precision or 1-6 digits from whole number

### Interlock

Allows you to use the Emergency Stop terminal on the 1, 3 and 8 channel communication expansion boards. Requires an external switch for actuation.

*Interlock Connection* Enabled/Disable Interlock through Auxiliary board

None Nothing is selected  
Interlock\_1 Enable Interlock through Auxiliary board

*Interlock Test* Run Interlock test

**\*\*NOTE: THE INTERLOCK MUST BE DISABLED TO ALLOW PRODUCT TRANSFER TO WORK\*\***

## LAMP INDICATOR

Allows you the use of the TCS 300365 External Lamp Assembly or other external Lamps to indicate all Sensor failures and Water Sensor warnings.

Lamp Enable/Disable	Enable or disable for operation. If enabled, you must reboot the register for the settings to be recognized.
Lamp Type	Select either Single Color (TCS 300365) or Tri-Color RYG Lamp
Lamp Test	Select from OK, Standby, Check (Alert), Alarm, Stop and Lamp off to verify testing.
	NOTE: if you have not rebooted the TCS 3000 register after Enabling operation, the Lamp Test will not operate correctly.
Lamp Address	Assign the address of each Lamp Indicator.

**CONNECTIVITY** Connectivity is used for accessory communication settings

### Network Settings

Interface Bridge Interface is for handheld communication. An interface is required for this setting. You must Enable or Disable the Interface Bridge accordingly.

Address Device Address will assign the TCS 3000 the unique address within the Daisy Chain communication sequence. It is recommended to assign addresses as follows:

- Primary Host will always be number one (1)
- Client Address range will be programmed from two (2) through eight (8).

NOTE: Client Address range can reach as many as one hundred and twenty seven (127), however this will slow the processor down. Eight is recommended number of registers in the daisy chain.

TCP Service	Enable/Disable TCP Remote Display	Enable or disable for operation
	Broadcasting Port	Port set for broadcasting delivery screen
	Broadcasting Mode	Set to Full or Selected Commands
	Select Variables	Configure the delivery screen type for display
Network	WiFi	
	Enable/Disable WiFi	Enable or disable WiFi module
	Connection Manager	Choose saved network, add new, or remove network
	WiFi Config	
	WiFi Mode	Select between WiFi client or Access Point
	AP Config	Configure access point options
		++ Changing WiFi Config will reboot register++
	Ethernet	
	DHCP Mode	Option to automatically set IP address from network in DHCP Mode or manually set IP address.
	Manual Set	Enter IP address for the 3000 register. If DHCP Mode is enabled, you will only be able to enter DNS addresses.

### Printer Settings

NOTE: Same settings as shown on page 12

Enable/Disable	Enable or Disable for operation
Select Printer	Select desired printer to be used with the system
Printer Host	Enable or Disable a printer host
	Clients Address Range Displays the range between Client Address range.

### RI Settings (Remote Interface)

Select Mode Remote Interface over RS or TCP protocol, then enter port if on TCP.

---

## CONFIGURE TICKET HEADERS/FOOTERS

DLV Header Defaults	There are FIVE programmable fields for contact information or messages
DLV Footer Defaults	There are FIVE programmable fields for contact information or messages
Shift Tickets Headers	There are FIVE programmable fields for contact information or messages
Inventory Tickets Headers	There are FIVE programmable fields for contact information or messages
Prover Tickets Headers	There are FIVE programmable fields for contact information or messages

## MISC SETTINGS

**L1 Password** Level one (1) password protection for System Settings, Product Settings and Advanced Functions .

Procedure to set L1 Password is as follows:

1. Highlight L1 Password and press ENTER.
2. Highlight Set Password and press ENTER.
3. Input alphanumeric password and press ENTER.
4. Confirm password entry by resubmitting password, and press ENTER.

NOTE: Alphanumeric password must be at least three (3) characters long.

**L2 Password** Level two (2) password protection for User ID Management

Procedure to set L2 Password is as follows:

1. Highlight L2 Password and press ENTER.
2. Highlight Set Password and press ENTER.
3. Input alphanumeric password and press ENTER.
4. Confirm password entry by resubmitting password, and press ENTER.

NOTE: Alphanumeric password must be at least three (3) characters long.

**Access Key (Password)** Access Key is used to lock or unlock the register keyboard when a SYSTEM INTERLOCK failure has occurred or when a Computer or Handheld device is in use.

**System Mode** System Mode is used for databases

Default	Used for standard register mode
MR1	Used for user ID database management. Once Enabled, USER ID MANAGEMENT will display on the Main Menu. See page 40 to create or delete entries.
RPA1 Mode	Used for remote programming

**User DB Update** Used to update the database. A portable USB memory drive loaded only with a factory database file must be uploaded through the USB terminal located within the Register.

**Startup Logo** Change the logo that will display while the 3000 is booting up.

Default	Generic TCS Logo
Save A Life	Save A Life Logo

**Hardware Tests** Enables the outputs for the provided options to test signal and voltage

Air Eliminator	Enables output signal for Air Elim and Aux 2
Transfer Key	Enables output signal for Product Transfer
Interlock	Enables output signal for connected Interlock switch installed on channel board

---

# Weights & Measures Settings

NOTE: The Calibration bolt must be removed in order to enter calibration mode. To remove the bolt, unscrew the bolt with a 3mm Hex drive (Generation 1) or a 5mm Hex Drive (Generation 2). Place Generation 1 calibration plate and screw in a safe location where it will not be lost. Under the calibration plate you will find a screw. Using the 3mm Hex drive, loosen the calibration screw. You do not need to remove this screw all the way.

++ If you lose the calibration screw, you will not be able to begin another delivery ++

DO NOT LOSE THIS CALIBRATION SCREW

BEFORE YOU CALIBRATE THE REGISTER YOU MUST ENTER A PRODUCT  
To Calibrate begin in section ADD NEW on Page 29.

**\*\*NOTE: ALL PRODUCTS MUST BE CALIBRATED INDIVIDUALLY\*\***

## PRODUCTS

### Recalibrate Product

Select Product            Highlight the product you want to re-calibrate and select ENTER.

NOTE: If you need to modify the settings you originally selected for the calibration of a product select MODIFY PARAMETERS, if the settings were correct and you do not need to change them select BEGIN RECALIBRATION.

### Modify Parameters

- |                    |   |
|--------------------|---|
| Product Name       | Using the keypad type in the name of the product you are calibrating. If the product listed is correct select ENTER. To change the product name press Enter and input name as desired. The menu screen will provide instructions on how to input your Alpha-Numeric keys. |
| Compensation Table | Choose the correct Volume Temperature Compensation Table and press ENTER.   |
| Comp. Table Param. | Input the correct Compensation Table Parameter and press ENTER. Selection will guide you through the tables settings and range. See following tables for reference. NOTE: this list references most common products, not an exhaustive list of every volume correction.   |
| NONE               | No volume compensation will be corrected.   |
| LINEAR_15C         | Input the product specific Coefficient of Expansion to 15C  |
| LINEAR_20C         | Input the product specific Coefficient of Expansion to 20C  |
| LINEAR_60F         | Input the product specific Coefficient of Expansion to 60F<br>See TABLE 2 for reference.  |
| API TABLES         | 24, 54, 54B, 54B, 54C, 54D, 54E and 6B<br>See TABLE 3 for reference.  |

NOTE: Temperature Compensation Table Parameters will illustrate the following:

Table Chosen	Density
Table Type	Parameter Unit
Temperature Unit	Parameter Scale
Reference Temperature	Minimum Value
Minimum Temperature	Maximum Value
Maximum Temperature	Parameter Value

TABLE 2

Product Name	COEFFICIENT OF EXPANSION	
	Per Degree Fahrenheit	Per Degree Celsius
Acetone	0.001	0.001416
Antifreeze	0.00036	0.00065
Benzene	0.0006	0.00108
Bunker C	0.00045	0.00081
Corn Syrup	0.00017	0.000306
Ethanol	0.0006	0.001072
Ethylene Glycol	0.00036	0.000648
Isopropyl Alcohol	0.001	0.001016
Lubrication Oils	0.004	0.0072
Methanol	0.00066	0.001180
Methyl Ethyl Ketone	0.00073	0.001314
Mineral Spirits	0.00056	0.001008
Naphtha	0.00072	0.001296
NH3	0.0013	0.00234
Propylene Glycol	0.0004	0.00072
Water	0.0002	0.00036

To compute the change in volume for a temperature change for a given

To convert from Coefficient of Expansion per Degree Fahrenheit to

$$(\Delta t)(\text{Coefficient of Expansion})(100) = \% \text{ change in volume}$$

TABLE 3

Product Name	API Table	Temp.	Coefficient Value	Range	Standard Density (kg/m <sup>3</sup> ) at 15C
Liquefied Propane Gas (LPG)	24	F	Specific Gravity	0.500 - 0.550	
Gasoline	54B	C	Density KG/m <sup>3</sup>	640 - 780	730
Diesel Oil	54B	C	Density KG/m <sup>3</sup>	780 - 1074	840
Fuel Oil	54B	C	Density KG/m <sup>3</sup>	830 - 900	840
Kerosene / Jet Fuel	54B	C	Density KG/m <sup>3</sup>	780 - 840	800
Stoddard Solvent	54B	C	Density KG/m <sup>3</sup>	780 - 800	840
Ethanol	54C	C	1e-6 Density KG/m <sup>3</sup>	414—1677	0.001072
Methanol	54C	C	1e-6 Density KG/m <sup>3</sup>	414—1677	0.001188
Lubricating Oils	54D	C	Density KG/m <sup>3</sup>	850 - 905	880
Natural Gas Liquids (NGL)	54E	C	Density KG/m <sup>3</sup>	352 - 687	468
Liquefied Propane Gas (LPG)	54	C	Density KG/m <sup>3</sup>	495 - 520	510
Fuel Oil	6B	F	API Gravity	32 - 35	
Gasoline	6B	F	API Gravity	62 - 65.1	
Premium Gasoline	6B	F	API Gravity	59.1	
Diesel	6B	F	API Gravity	32 - 35	
Kerosene	6B	F	API Gravity	42	
Jet A/A1	6B	F	API Gravity	41.9 - 42.9	
Av Gas	6B	F	API Gravity	42 - 44	
Refined Fuels	6B	F	API Gravity	0 - 85	

---

**Mass Density**

To provide a manual calculated Mass value, determine the value to input Mass Density and press ENTER. NOTE: only provide value if not using a Densitometer.

**Mass = Weight per Volume**

Unit of Measure	
Gram/cm3	Gram/Cubic Centimeter
Gram/m3	Gram/Cubic Meter
Kilogram/m3	Kilogram/Cubic Meter
Milligram/m3	Milligram/Cubic Meter
Pound/ft3	Pound/Cubic Foot
Pound/in3	Pound/Cubic Inch
Ton/yard3	Ton/Cubic Yard

**Pump Control & Timing**

Enable/Disable Pump Control and select ENTER.

- Pump is an Optional Output Control
- Enabled means that the pump control will energize a PTO or Hydraulic Drive during a truck delivery.
- Disabled means that the pump control is not active and will not energize.

Pump Speed Control 1 is a solid state voltage output signal based on a flow rate setting. Flow rate setting of zero (0) is disabled. Utilizes the Pump Starter terminal. NOTE: Pump Speed Control overwrites the Additive Pump setting.

Pump Speed Control 2 is a solid state voltage output signal based on a flow rate setting. Utilizes the Reset terminal. Flow rate setting of zero (0) is disabled.

**Valve Type**

Select whether you are using a Single or Dual Stage Valve and press ENTER.

- A SINGLE Stage valve will energize valve with Solenoid 2.
- A DUAL Stage valve will energize valve with Solenoids 1 and 2.

1101 Both S1 and S2 energize at the beginning of delivery and near the end of the delivery S1 shuts off and S2 is still operating.

1001 At the beginning of the delivery the S1 valve opens energizes while the S2 remains closed. When the preset slow flow bypass begins, the S1 valve closes and the slow flow bypass valve S2 opens until the end of the delivery.

**S1 - S2 Delay**

Timing of the S1 valve opening at the start of a delivery. Enter S1 time value (minimum of 3 seconds).

**Maximum Flowrate**

Input the maximum rated flow of flow meter and press ENTER.

NOTE: this value is critical to the Valve actuation!

---

**Flowrate Limits**      Delivery shutdown threshold for Minimum, Maximum and Safety Limits

Minimum Flow Rate      Minimum capacity of flow meter and set time before shutdown  
Maximum Flow Rate      Maximum capacity of flow meter and set time before shutdown  
Flowrate Safety Limit      Overflow capacity shutdown flow rate

**S2 Flow**      Timing of the S2 valve closure rate. Enter S2 time value (minimum 0.3 seconds).

**Pulser Type**      Select the pulse input type (Single or Dual Channel) and press ENTER.

SINGLE is a single channel pulse input.

DUAL is a dual channel pulse input.

Chose FORWARD or REVERSE for the direction of flow.

QUAD is a dual channel pulse input multiplied by two.

Chose FORWARD or REVERSE for the direction of flow.

**Product Units**      Select TCS 3000 register units of measure and press ENTER.

Volume      Highlight Volume Unit and press ENTER.

GAL	US Gallon
L	Liter
UKG	UK Gallon
daL	Decaliter
dL	Deciliter
cL	Centiliter
mL	Milliliter
m3	Cubic Meter
cm3	Cubic Centimeter
cc	Cubic Centimeter
bbL	Barrel
fLoz	Fluid Ounce
ft3	Cubic Foot
in3	Cubic Inch

NOTE: Selecting Product Unit does not change the Totalizer unit of measure. See Page 32 for changing Totalizer unit of measure.

Temperature      Select from Fahrenheit, Celsius or Kelvin

Currency      Symbols:      Select from None, \$, £, ¥ or Rp  
Abbreviation:      International three (3) digit code

None	-
\$	US Gallons
£	Pound
¥	Yen
Rp	Rupee

**\*\*NOTE: Pound and Yen symbols are NOT supported on EPSON brand printers.\*\***

Mass      Select mass unit

lbs	US Pound
oz	US Ounce
t	US ton
kg	Kilogram
g	Gram

---

**Density****Select density unit**

lbs/Gal	US Pounds per Gallon
kg/m <sup>3</sup>	Kilograms per Cubic Meter
kg/L	Kilograms per Liter
lbs/UKG	UK Pounds per Gallons
lbs/ft <sup>3</sup>	US Pounds per Cubic Foot
lbs/in <sup>3</sup>	US Pounds per Cubic Inches
lbs/floz	US Pounds per Fluid Ounce
oz/floz	Ounce per Fluid Ounce

**Additive****Select additive unit**

mL	Milliliter
cm <sup>3</sup>	Cubic Centimeter
Cc	Cubic Centimeter
cL	Centiliter
dL	Deciliter
L	Liter
in <sup>3</sup>	Cubic Inch
floz	Fluid Oz
GAL	US Gallon

**Hose Volume**

Enter unit volume value for “packing” hose downstream of meter and press ENTER. Value will not display prior to setting and there will be no lost liquid. See Page 29 for Enabling.

To comply with Weights & Measures requirements, it is necessary to start and stop each delivery with a fully packed hose. There are times where the hose is not fully packed (e.g. after a preset delivery). As such, the hose must be packed and the register zeroed prior to making the next deliver.

NOTE: This procedure will not work for an empty or dry hose. If more than 1 gallon or 5 Liters of liquid is required to pack the hose, a delivery ticket must be printed.

**Maximum Pulser Error** Program the amount of reverse pulse counts the register is allowed to see before it | shuts the system down. NOTE: Maximum value is 255.

**Additive Injector**

Injection Ratio is the additive concentration rate by volume. As an example, the parts per million injected into the product calculated as Parts Per Million (PPM). The treat rate is divided by the second number and the result is multiplied by 1,000,000.

Example: 1:1500 Treat Rate is calculated by  $1/1500 = 0.000667 \times 1,000,000 = 667$  PPM

**Injector Type** NONE No Injector

**EXTERNAL** A constant positive signal output is provided during product delivery.  
NOTE: An external additive Injector controls injection pump rate.

**INJECTION LIMITS** - Enable/Disable Injection Limit for delivery shutdown.  
Enter Minimum and Maximum Concentration Rate to end delivery  
Enter Additive Injection Stabilization Volume to stabilize the rate at the beginning of a delivery.

EXAMPLE: GTP Viper Injector pump will dose nearly every 5 gallons. Without an additive injection dose within the first 5 gallons, the minimum rate threshold will stop the delivery.

**ADDITIVE LABEL** - A text field for a user defined additive name. The additive label does not automatically print on a delivery ticket. The additive label must be inserted into the configured ticket.

**INJECTOR CALIBRATION**

INJ Pulses/Unit (Enter Injection Volume).

Use the following calculation to adjust the flow meter calibration factor:

$$\text{Corrected Calibration Factor} = \frac{\text{Current Pulse Factor multiplied by Volume on Meter Display}}{\text{Delivered Volume on Prover}}$$

**++ NOTE: CHANGING ADDITIVE CALIBRATION WILL NOT INCREASE/DECREASE INJECTION VOLUME. PLEASE REVIEW GAMMON TECHNICAL PRODUCTS (GTP) INSTRUCTIONS FOR INJECTION PUMP ADJUSTMENT ++**

INJ Volume Unit - Change the volume unit used for the additive  
INJ Pulser Type - Dual or Single

**PISTON** A pulsing positive signal output is provided during product delivery.

**INJECTION RATIO** - Enter desired Concentration Rate volume target.  
**INJECTION LIMITS** - Enable/Disable Injection Limit for delivery shutdown.  
Enter Minimum and Maximum rate to end delivery  
Enter Additive Injection Stabilization Volume to stabilize the rate at the beginning of a delivery.

**ADDITIVE LABEL** - A text field for a user defined additive name. The additive label does not automatically print on a delivery ticket. The additive label must be inserted into the configured ticket.

**INJECTION CALIBRATION**

CALIBRATE - UNAVAILABLE AT THIS TIME

EDIT/VIEW PARAMETERS - Manually Calibrate the Additive Injector

INJ Pulses/Unit (Enter Injection Volume). Use the following calculation to adjust the flow meter calibration factor:

$$\text{Corrected Calibration Factor} = \frac{\text{Current Pulse Factor multiplied by Volume on Meter Display}}{\text{Delivered Volume on Prover}}$$

INJ Volume Unit - Change the volume unit used for the additive  
INJ Pulser Type - Dual or Single

Min. Inj. Period - Time required for injection (mS). EXAMPLE: 700 mS

Injection Portion - Set volume between each dose. This should be the additive Meter Pulse Factor multiplied by 10.

PRESSURE An additive injection signal output for an injection pump, additive meter and controlling the injection ratio with a control valve during delivery.

INJECTION RATIO - Enter desired Concentration Rate volume target.

INJECTION LIMITS - Enable/Disable Injection Limit for delivery shutdown.  
Enter Minimum and Maximum rate to end delivery  
Enter Additive Injection Stabilization Volume to stabilize the rate at the beginning of a delivery.

ADDITIVE LABEL - A text field for a user defined additive name. The additive label does not automatically print on a delivery ticket. The additive label must be inserted into the configured ticket.

#### INJECTION CALIBRATION

CALIBRATE - UNAVAILABLE AT THIS TIME

EDIT/VIEW PARAMETERS - Manually Calibrate the Additive Injector

INJ Pulses/Unit (Enter Injection Volume).

Use the following calculation to adjust the flow meter calibration factor:

$$\text{Corrected Calibration Factor} = \frac{\text{Current Pulse Factor multiplied by Volume on Meter Display}}{\text{Delivered Volume on Prover}}$$

**++ NOTE: A CALIBRATION IS REQUIRED AFTER EACH ADJUSTMENT OF THE BYPASS VALVE ++**

INJ Volume Unit - Change the volume unit used for the additive

INJ Pulser Type - Dual or Single

Min. Inj. Period - Time required for injection (mS). EXAMPLE: 700 mS

Injection Portion - Set volume between each dose. This should be the Additive Meter Pulse Factor multiplied by 10

#### BEGIN RECALIBRATION

**\*\*NOTE: ALL PRODUCTS MUST BE CALIBRATED INDIVIDUALLY\*\***

**FULL CALIBRATION:** Select Full Calibration to clear old calibration value(s) and establish a new calibration point for Product.

- 1) The display will prompt you to press START to begin automatic calibration of the flow meter. Press STOP when finished with a certified Weights & Measures volumetric or gravimetric proving system.
- 2) Input Prover Value and press ENTER. A Calibration Summary screen will appear with the Gross Amount, Net Amount, Average Temperature, Compensation Table, Pulse/Second and *Pulse/Volume (Meter Calibration Value)*.
- 3) Press START to Accept calibration value.
- 4) The display will ask if you would like to store this point. Enter to Store the calibration value or press Mode to run calibration over again.  
NOTE: failure to Store the calibration value will loose the calibration data and require you to run the FULL CALIBRATION over again.

**ADD POINT:** Select Add Point to create a Multi-Point Calibration curve over the entire flow range of the flow meter. The minimum points required are two (2) and one hundred (100) is your maximum points accepted.

- 1) Select Add Point to add an addition point at a specific flow rate to linearize your calibration curve from minimum to maximum flow rates.
- 2) The display will prompt you to press START to begin automatic calibration of the flow meter. Press STOP when finished with a certified Weights & Measures volumetric or gravimetric proving system.
- 3) Input Prover Value and press ENTER. A Calibration Summary screen will appear with the Gross Amount, Net Amount, Average Temperature, Compensation Table, Pulse/Second and *Pulse/Volume (Meter Calibration Value)*.
- 4) Press START to Accept calibration value.
- 5) The display will ask if you would like to store this point. Enter to Store the calibration value or press Mode to run calibration over again.  
NOTE: failure to Store the calibration value will loose the calibration data and require you to run the ADD POINT over again.

**Perform Test Run** Press Shift + Start to begin a test run and verify the calibration. This option will not perform any changes to your calibration.

During the activation of a Test Run, the following outputs should activate if Enabled:

*Pump Control*  
*Speed Control 1 & 2*  
*Solenoid 1 & 2*

**\*\* NOTE: NOT ALL SIGNAL OUTPUT FUNCTIONS WILL WORK DURING A TEST RUN \*\***

#### **EDIT PRODUCT CALIBRATION**

Allows a manual calibration modification of each flow rate point, after a calibration has already been established. You may build a linear "multipoint" calibration curve. A "WARNING" screen will then be displayed, press ENTER to continue to change Meter Calibration Value.

**Modify Point** Select Product to manually change Meter Calibration Value. Select Calibration Point (Tested Flow Rate) to adjust the current Meter Calibration Value with the following equation:

$$\text{Corrected Calibration Factor} = \frac{\text{Current Pulse Factor multiplied by Volume on Meter Display}}{\text{Volume on Prover}}$$

*Edit Point* Change the existing pulser coefficient value  
- Keep Original This will allow you to keep the original flow rate  
- Recalculate This will recalculate the original flow rate based on the new pulser coefficient value.

*Delete Point* Removes the calibration flow rate and pulser coefficient value

**Add New Point** Enter a new flow rate to linearize the calibration curve. Use 10% increments for each flow rate. Enter a pulser coefficient value.

**\*\* Always double check to make sure the product calibration value was changed correctly \*\***

## Total Control Systems - Meter Pulse Value Factors

FLOW METER	PULSE CHANNEL	TCS 3000 75/90 DEGREE MOUNT		Direct Mount Pulsar 100:1 TCS 3000 REMOTE MOUNT		Direct Mount Pulsar 250:1 TCS 3000 REMOTE MOUNT	
		TCS 3000 75/90 DEGREE MOUNT	TCS 3000 75/90 DEGREE MOUNT	400.0 Pulses/USG	105.7 Pulses/LTR	1000.0 Pulses/USG	264.3 Pulses/LTR
682-15	Single	400.0 Pulses/USG	105.7 Pulses/LTR	400.0 Pulses/USG	105.7 Pulses/LTR	1000.0 Pulses/USG	264.3 Pulses/LTR
	Dual	800.0 Pulses/USG	211.4 Pulses/LTR	800.0 Pulses/USG	211.4 Pulses/LTR	2000.0 Pulses/USG	528.5 Pulses/LTR
	Quadrature	1600.0 Pulses/USG	422.8 Pulses/LTR	1600.0 Pulses/USG	422.8 Pulses/LTR	4000.0 Pulses/USG	1057.0 Pulses/LTR

FLOW METER	PULSE CHANNEL	4:1 Packing Gland (Standard) TCS 3000 75/90 DEGREE MOUNT		Direct Mount Pulsar 100:1 TCS 3000 REMOTE MOUNT		Direct Mount Pulsar 250:1 TCS 3000 REMOTE MOUNT	
		TCS 3000 75/90 DEGREE MOUNT	TCS 3000 75/90 DEGREE MOUNT	1223.7 Pulses/USG	323.3 Pulses/LTR	3059.3 Pulses/USG	808.3 Pulses/LTR
700-15	Single	305.9 Pulses/USG	80.8 Pulses/LTR	1223.7 Pulses/USG	323.3 Pulses/LTR	3059.3 Pulses/USG	808.3 Pulses/LTR
	Dual	611.6 Pulses/USG	161.6 Pulses/LTR	2446.4 Pulses/USG	646.3 Pulses/LTR	6116.0 Pulses/USG	1615.8 Pulses/LTR
	Quadrature	1223.2 Pulses/USG	323.4 Pulses/LTR	4892.8 Pulses/USG	1223.5 Pulses/LTR	12232.0 Pulses/USG	3233.8 Pulses/LTR

FLOW METER	PULSE CHANNEL	2:1 Packing Gland (Standard) TCS 3000 75/90 DEGREE MOUNT		1:1 Packing Gland TCS 3000 75/90 DEGREE MOUNT		Direct Mount Pulsar 100:1 TCS 3000 REMOTE MOUNT		Direct Mount Pulsar 250:1 TCS 3000 REMOTE MOUNT	
		TCS 3000 75/90 DEGREE MOUNT	TCS 3000 75/90 DEGREE MOUNT	TCS 3000 75/90 DEGREE MOUNT	TCS 3000 75/90 DEGREE MOUNT	555.5 Pulses/USG	146.8 Pulses/LTR	1388.8 Pulses/USG	367.0 Pulses/LTR
700-20/25	Single	277.75 Pulses/USG	73.4 Pulses/LTR	555.5 Pulses/USG	146.8 Pulses/LTR	555.5 Pulses/USG	146.8 Pulses/LTR	1388.8 Pulses/USG	367.0 Pulses/LTR
	Dual	555.5 Pulses/USG	146.8 Pulses/LTR	1111.0 Pulses/USG	293.6 Pulses/LTR	1111.0 Pulses/USG	293.6 Pulses/LTR	2777.5 Pulses/USG	734.0 Pulses/LTR
	Quadrature	1111.0 Pulses/USG	293.6 Pulses/LTR	2222.0 Pulses/USG	587.2 Pulses/LTR	2222.0 Pulses/USG	587.2 Pulses/LTR	5555.5 Pulses/USG	1468.0 Pulses/LTR
700-30/35	Single	102.9 Pulses/USG	27.2 Pulses/LTR	205.8 Pulses/USG	54.4 Pulses/LTR	205.8 Pulses/USG	54.4 Pulses/LTR	514.5 Pulses/USG	136.0 Pulses/LTR
	Dual	205.8 Pulses/USG	54.4 Pulses/LTR	411.6 Pulses/USG	108.8 Pulses/LTR	411.6 Pulses/USG	108.8 Pulses/LTR	1029.0 Pulses/USG	272.0 Pulses/LTR
	Quadrature	411.6 Pulses/USG	108.8 Pulses/LTR	823.2 Pulses/USG	217.6 Pulses/LTR	823.2 Pulses/USG	217.6 Pulses/LTR	2058.0 Pulses/USG	544.0 Pulses/LTR
700-40/45	Single	37.1 Pulses/USG	9.8 Pulses/LTR	74.2 Pulses/USG	19.6 Pulses/LTR	74.2 Pulses/USG	19.6 Pulses/LTR	185.5 Pulses/USG	49.0 Pulses/LTR
	Dual	74.2 Pulses/USG	19.6 Pulses/LTR	148.4 Pulses/USG	39.2 Pulses/LTR	148.4 Pulses/USG	39.2 Pulses/LTR	371.0 Pulses/USG	98.0 Pulses/LTR
	Quadrature	148.4 Pulses/USG	39.2 Pulses/LTR	296.8 Pulses/USG	78.4 Pulses/LTR	296.8 Pulses/USG	78.4 Pulses/LTR	742.0 Pulses/USG	196.0 Pulses/LTR
700-60/65	Single	18.55 Pulses/USG	4.9 Pulses/LTR	37.1 Pulses/USG	9.8 Pulses/LTR	37.1 Pulses/USG	9.8 Pulses/LTR	92.8 Pulses/USG	24.5 Pulses/LTR
	Dual	37.1 Pulses/USG	9.8 Pulses/LTR	74.2 Pulses/USG	19.6 Pulses/LTR	74.2 Pulses/USG	19.6 Pulses/LTR	185.5 Pulses/USG	49.0 Pulses/LTR
	Quadrature	74.2 Pulses/USG	19.6 Pulses/LTR	148.4 Pulses/USG	39.2 Pulses/LTR	148.4 Pulses/USG	39.2 Pulses/LTR	371.0 Pulses/USG	98.0 Pulses/LTR

## Add New

Before you can calibrate the register, you must enter a product. Select Add New and use the keypad to enter a product (e.g. LPG, Fuel Oil, Aviation Gasoline, etc.). Once you've entered your product, press ENTER.

All parameters for a New Product MUST be entered for the product to be accepted by the TCS 3000. Follow pages 20 through 26, under Modify Parameters to complete the Add New product setup. Once the new product parameters have been entered, you will be required to calibrate the product.

NOTE: A new product MUST be calibrated for it to be available as an Active product. Without calibration, the new product will only be seen in Product Settings LIST.

## Remove Product

To remove an unwanted product from the TCS 3000, select and press ENTER. To confirm product removal, press MODE.

NOTE: You must first End Shift and then Deactivate the product under Product Settings. You can however remove a deactivated product during an Active Shift

## Hose Charge

Enable or Disable the Hose Charge at beginning of delivery. Adjustment to the Hose Charge volume is made under the Product Hose Volume seen on page 24.

## ACCOUNTING

Select Accounting to set the Ticket Number and Configure Tickets.

### Next Ticket No.

Select Next Ticket No. to program the next delivery ticket number.

NOTE: Delivery must be completed after changing the next ticket number and prior to the TCS 3000 register is turned off for it to take effect.

### Require Ticket Print

Select Require Ticket Print to require the user to print a ticket after every transaction.

### Configure Tickets

#### Select Ticket Type

Sets the DEFAULT for the delivery ticket. If you create a new Ticket, you must choose the configured ticket as your default printed ticket. *NOTE: A MINIMUM ticket must be stored as a ticket type. Pre-configured tickets are available to choose from:*

MAXIMUM	Allows the maximum amount of space on the ticket.
MINIMUM	Allows the minimum amount of space to be used on the ticket.

### Customize Ticket

Allows you to customize the preconfigured information printed on the delivery ticket. Choose from the following.

TCS 3000 Menu	Example Prints
Header 1	Total Control Systems
Header 2	TCS 3000
Header 3	Delivery Ticket
Header 4	(888) 888-8888
Header 5	Programmable Field
Thick Separator	-----
Start Time	Start Jun 04, 2012 09:42:09 AM
End Time	End Jun 04, 2012 09:53:42 AM
Truck ID	3842 - Meter 2
Ticket Number	#####
Product Name	Gasoline (Product setup in Prover)
ProdNet Total Begin	#####
ProdNet Totalizer	#####
ProdGrs Total Begin	#####
ProdGrs Totalizer	#####
SysNet Total Begin	#####
SysNet Totalizer	#####
SysGrs Total. Begin	#####
SysGrs Totalizer	#####
Delivery Section	-- Delivery --
Selectable DB1	Selectable Database 1
Selectable DB2	Selectable Database 2

CONFIGURE TICKETS CONTINUED...



Customer ID 1	Programmable Field
Customer ID 2	Programmable Field
Customer ID 3	Programmable Field
Customer ID 4	Programmable Field
Customer ID 5	
Customer ID 6	Programmable Field
Line	
Delivery Gross Begin	#####
Delivery Gross End	#####
Delivery Net Begin	#####
Delivery Net End	#####
TempComp Line	Volume Corrected to 60F (15C)
Tempcomp Table	Table — i.e. Table 24
Tempcomp Param	i.e. 780 kg/m3
Average Temp	AVG Temp. F
Gross Delivered	Gross Gal. Delivered
Net Delivered	Net Gal. Delivered
Line	
Inventory Name	i. e. Tank 1 Diesel
Inventory Begin	#####
Inventory End	#####
Inventory	#####
Peak Corrected Differential Pressure (CDP)	i.e. 30 PSI
Average Corr. Diff. Pressure	i.e. 14 PSI
Average Flow Rate	i.e. 100 GPM
Peak Flow Rate	i.e. 130 GPM
Flow at Peak CDP	i.e. 130 GPM
Additive Label	i.e. FSII
Additive Volume	i.e. 200 mL
Additive Ratio	i.e. 1000 PPM
Peak H2O Content	i.e. 15 PPM
Average H2O Content	i.e. 10 PPM
Average Density	i.e. 6.82 lbs/GAL
Minimum Density	i.e. 6.76 lbs/GAL
Peak Density	i.e. 7.18 lbs/GAL
Calculated Mass	i.e. 830 lbs
System Mass Totalizer	#####
Product Mass Totalizer	#####
Unit Price	Unit Price — i.e. 1.86
Sale Amount	#####
Tax 1	Tax 1 — i.e. Road Tax
Tax 2	Tax 2 — i.e. Sales Tax
Tax Amount	Tax Amount
Star Line	*****
Amount Due	Amount Due — — — — ##.##
Empty Line	#####
Signature Line	<i>John C. Polito</i>
Thick Separator	-----
System Line 1	** Duplicate Invoice **
System Line 2	*** Power Loss ***
System Line 3	*** Maximum H2O Concentration Too High ***
Footer 1	Programmable Field
Footer 2	Programmable Field
Footer 3	Programmable Field
Footer 4	Programmable Field
Footer 5	Programmable Field

Add Ticket Type	Create a NEW Customized Ticket, then press ENTER to name it. Copy from an Existing Ticket, then press ENTER to name it. <i>NOTE:</i> Any new ticket name must be 3 or more characters long
Remove Ticket Type	Select ticket to be removed from the system and press ENTER
Header Defaults	There are FIVE programmable fields for contact information or messages
Footer Defaults	There are FIVE programmable fields for contact information or messages
Shift Ticket Headers	There are FIVE programmable fields for contact information or messages
Inventory Tickets Headers	There are FIVE programmable fields for contact information or messages
Prover Ticket Headers	There are FIVE programmable fields for contact information of messages
Required System Lines	Enable or Disable system generated lines that display on tickets

## DELIVERY SCREENS

- Configure Type 1** Using the arrow keys to move Red Cursor around the screen, highlight the field you would like to change and select ENTER. The field options are in Table 1 below.
- Configure Type 2** Using the arrow keys to move Red Cursor around the screen, highlight the field you would like to change and select ENTER. The field options are in Table 1 below.
- Configure Type 3** Using the arrow keys to move Red Cursor around the screen, highlight the field you would like to change and select ENTER. The field options are in Table 1 below.
- Configure Type 4** Not configurable by itself. Displays the large screen field option for Configuration Type 3.
- Configure Type 5** Using the arrow keys to move Red Cursor around the screen, highlight the field you would like to change and select ENTER. The field options are in Table 1 below.

TYPE 1

Feb 16, 2012 06:35:07 PM	System Gross Gal 0.0
 	System Net Gal 0.0
<b>TOTAL \$</b>	<b>0.00</b>
<b>PRODUCT</b>	<b>Volume</b>
	<b>0.0</b>
<b>SELECT = ENTER; EXIT = CANCEL</b>	
Flowrate Gal/min 0.0	Volume Gal 0.0
Preset Gal 0.0	Remain Gal 0.0
PrstAmnt \$ 0.00	Price \$/Gal 0.00
AVG Temp F 0.0	Temp F 0.0

TYPE 2

Jan 28, 2013 12:54:04 PM	System Gross Gal 0.0
 	
<b>Gross Gal</b>	<b>0.0</b>
<b>PRODUCT</b>	<b>Volume</b>
	<b>0.0</b>
<b>SELECT = ENTER; EXIT = CANCEL</b>	
Flowrate Gal/min 0.0	TOTAL \$ 0.00
AVG Temp F 0.0	Temp F 0.0

TYPE 3

Feb 16, 2012 06:34:34 PM	System Gross Gal 0.0
 	System Net Gal 0.0
<b>Remain Gal</b>	<b>0.0</b>
	<b>0.0</b>
<b>SELECT = ENTER; EXIT = CANCEL</b>	

TYPE 4

Jan 30, 2014 05:35:51 PM	System Gross GAL 3575.0
 	
<b>Gross GAL</b>	
<b>1234</b>	

TYPE 5

May 03, 2019 03:54:17 PM	System Gross GAL 87425.7
<b>JET W/ADDITIVE</b>	<b>Gross</b>
<b>355.6</b>	
<b>START-START DELIVERY, PRINT-PRINT TICKET</b>	
Additive mL 1345.9	Flowrate GAL/min 0.0
Additive PPM 1000.0	PK. FLOW GAL/min 293.9

DISPLAY FIELD SELECTION TABLE 4 OPTIONS:

Empty	No Data
Product Name	(LPG, Diesel, Av Gas, Etc.)
Delivery Gross	Non-Compensated Delivery Total
Delivery Net	Compensated Delivery Total
Delivery Volume	Amount of Delivery
Delivery Total	Total Price Delivered
Flowrate	Amount Delivered through Per Minute
AVG Temperature	Average Temperature of Product
Temperature	Temperature of Product
Mass	Mass of the Product (e.g. Pounds per Gallon, etc.)
Preset Remain	Remaining Preset (What is left of the Preset Total)
Preset Volume	Preset Volume Amount for Delivery
Preset Amount	Preset Currency Amount for Delivery
Comp. Table	Compensation Table (6B, 54B, Etc.)
Unit Price	Unit Price
Calc. Price	Calculated Price
TAX1	Tax
TAX2	Tax
CORR. DP	Corrected DP (Correction for DP Gauge)
Peak CDP.	Maximum Correction of the DP Gauge
AVG. CDP	Average Correction of the DP Gauge
AVG FLOW	Average Flow Rate of the Register
PK. FLOW	The Highest Flow Rate of the Register Recorded
Massrate	Mass of the Product
Additive Volume	How much Product was injected during the Delivery (mL)
Additive Ratio	The Ratio of Additive to Product (mL)
WATER	The Water content displayed in real-time (PPM)
PEAK WATER	The Highest Water value achieved during delivery
AVG. WATER	Average Water PPM during delivery
PEAK DENSITY	The Highest Density value achieved during delivery
MIN. DENSITY	The Lowest Density value achieved during delivery
AVG. DENSITY	Average Density during delivery
DENSITY	Density of the Product

**SYSTEM METRICS**

**Precision** The unit precision can be displayed as a whole, tenth, hundredth or thousands measurement. After selection, press ENTER to complete setting (see below for precision options).

System Precision Change the number of decimal places for totalizer and delivery screens  
 Unit Price Precision Change the number of decimal places for product pricing  
 Additive Precision Change the number of decimal places for additive amounts  
 W&M Display Precision Change the number of decimal places for W&M menus

W&M Integer Display Change the amount of numbers before the decimal point  
 W&M Precision Change decimal places for calibrations

- 1 Whole Unit
- 1.1 Tenth Unit
- 1.11 Hundredth Unit
- 1.111 Thousands Unit

**System Totalizers** This function will allow display either a Volumetric or Mass Totalizer.

Select Volume or Mass and press ENTER. Then select the Unit of Measure.

NOTE: See page 23 for unit options

---

**TEMP PROBE**

This function is used to change the reference temperature of the liquid meter system RTD temperature probe.

**Calibrate Temp Probe**

Highlight Offset Calibration and press ENTER. Highlight Reference Temperature Unit of Measure and press ENTER.

TEMPERATURE	
C	Celsius
F	Fahrenheit
K	Kelvin

**Temp Probe Type**

TCS3000 or TCS3000EX

**Enbl DLV. W/O Probe**

Enable or Disable deliveries without the RTD temperature probe. Enable to prevent Net Volume deliveries defaulting to Gross volume if the RTD temperature probe loses communication with the register.

**++ NOTE: Must use a metrological traceable temperature probe for calibration ++**

**METER INFORMATION**

Selecting Meter Information allows you to enter the information off of your meter and register. This information is required for the Report Menu on page 10, as well as the Prover Tickets from Meter Calibration.

**Register #**

Highlight Register # and input the TCS 3000 serial number located on the unit. Press ENTER when complete.

**Truck ID**

Highlight Truck ID to input the truck or tank number. Press ENTER when complete. NOTE: if there are multiple meters daisy chained together, the Truck ID and Meter sequence number should be input here (i.e. Truck 5381 Meter 2).

**Meter Version**

Highlight Meter Version and enter the manufacture. Press ENTER when complete.

**Meter Make**

Highlight Meter Make and enter the meter manufacturer's name and Press ENTER when complete.

**Meter Model**

Highlight Meter Model and enter the assembly model number. Press ENTER when complete.

**Meter Serial #**

Highlight Meter Serial # and input the meter serial number of the unit. Press ENTER when complete.

**System ID**

Highlight System ID and input the system identification. Press ENTER when complete.

**PROVER TICKET**

Selecting Prover Ticket allows you to Print the existing Prover Data from the TCS 3000 register. Select PRINT to print the Prover Ticket.

**TICKETS CLEANUP**

Enabling Tickets Cleanup will allow the system to delete the oldest 500 non-printed tickets when there are more than 5000 non-printed tickets stored.

**RESET TOTALIZERS**

System and Product Totalizers record the amount of all liquid that has passed through the meter by product.

**\*\*NOTE: THERE IS NO WAY TO RECOVER TOTALIZERS ONCE THEY ARE CHANGED\*\***

**System Totalizer**

System Totalizers record the amount of all liquid that has been measured. End Shift before resetting the System Totalizer.

Reset to Zero  
Set Value

Reset Totalizer to 0 of the selected unit  
Set the Totalizer to a specific value (entered manually)

---

## Product Totalizer

Product Totalizers record the amount of liquid for a specific product that has been measured. You must End Shift (page 8) and Deactivate Product in Product Settings (page 37) before resetting the Product Totalizer. Without doing so, the error "No Active Products" will be displayed. Highlight Product Totalizer and press ENTER.

## ZERO FLOW TIMEOUT

Feature will complete a delivery transaction if the user does not press the STOP key. Enter number value in Seconds for the timeout setting and press ENTER.

NOTE: Factory setting is 180 seconds, 3 minutes after the last pulse transmission to the TCS 3000 register. This feature CANNOT be disabled. For desired extended periods, utilize a large number

## MISCELLANEOUS W&M

### Air Eliminator

The Air Eliminator is for the electronic actuation of a solenoid exhaust vent and a down stream valve, when a level sensor switches.

AE Enable/Disable	Enable or disable for operation
AE Detection	Select Normally Open or Closed for level sensor detection
AE Relay	Enable or disable exhaust vent solenoid valve actuation
AE Tests	Enables testing of the AE outputs/inputs on the terminal board

### Transfer Key

Used to select the type of Interlock being used for Product Transfer

Key Connection	Select what type of interlock will be used
<i>MB_KEY2</i>	Uses interlock built into TCS 3000 Motherboard
<i>INTERLOCK_1</i>	Uses external interlock connected to the TCS 3000

*++ NOTE: INTERLOCK\_1 WILL NOT WORK PROPERLY IF THE PAUSE FUNCTION IS DISABLED ++*

*++ NOTE: TRANSFER KEY REQUIRES SYSTEM LINE 1, 2 & 3 TO BE CONFIGURED ON DELIVERY TICKET ++*

Key Type	Select interlock switch between N/O and N/C
Test Key	Test interlock switch

### Pulser Tracker

Pulser Tracker tracks any flow between deliveries. Any time the pulser moves outside of a delivery the register captures the movement data.

*++ If Pulser Tracker is disable, any product movement without hitting start will not be recorded in the totalizer. ++*

### Test Pulser

The test pulser is used for diagnostics or simulation of a delivery. The test pulser is a software generated pulse that you can only vary though this setting.

Enable/Disable	Enable or disable the test pulser
Configure Fast Rate	You must enter a pulser coefficient value for the fast flow rate. Press Enter when finished. A lower pulse factor will equal a faster rate.
Configure Slow Rate	You must enter a pulser coefficient value for the slow rate. Press Enter when finished. A higher pulser factor will equal a slow flow rate.

### Additive Injector

Config Settings	Enable or Disable access to Additive Injector Settings outside of W&M Menu. <b>**The menu will be available inside the Product Settings (see page 38).**</b>
-----------------	---

### Enable Remote Config

Allows you to connect the TCS 3000 to an External Handheld device to remotely control the Calibration of the register.

- To Enable Remote Config make sure your External Handheld is connected to the TCS 3000 register with the TCS 300859 quick disconnect cable kit).
- Highlight Remote Config and select ENTER. This will enable the Remote Config setting and you will be able to calibrate your system.
- When finished calibrating, press any key to exit.

---

## W&M Test Menus

Tempcomp Test      Allows testing of each Temperature Compensation Table

## System Cloning

Allows you to generate a clone of the current configuration of the TCS 3000. Requires an empty FAT 32 formatted USB drive that is between 8-32 GB to be connected to the USB port on the 3000. **\*\*MUST ENTER L2 PASSWORD TO ACCESS MENU\*\***

It is recommended that all tickets be exported or transferred off of the 3000 before doing this; otherwise they will also appear on the generated clone file.

# Product Settings

## INVENTORY

Inventory monitors how much product is in a tank.

### View Inventory

Allows you to see your total inventory levels of numerous tanks on one display, See Individual inventory details, or print an Inventory Report.

Inventory Display	Displays the current inventory status
Select Inventory	Chose tank inventory to display inventory details
Print Inventory Report	Prints the current inventory report

### Update Inventory

Allows you to correct the Inventory levels by manually entering the proper inventory level. Select Inventory to update and press ENTER.

Add to Inventory	Add to Inventory allows you to add to the current inventory when you are loading "X" amount of product to the tank
Set Inventory Value	Set Inventory Value allows you to change the inventory level to a specific amount
Fill Up Inventory	Filling up the inventory to 100% Tank Capacity. <b>QUICK RESET - Press SHIFT + PRINT</b>
Empty Inventory	Emptying the Inventory to 0%.
Level Meter	Level Meter allows you to select the channel level meter being used.

++ Requires gauge to be calibrated, overriding the manual inventory entry ++

### Assign Inventory

Allows you to Pair an Active Product or Products to the Inventory Tank Created to be Monitored. You must reassign inventory to a product after each calibration.

**\*\*This must be done to track inventory levels\*\***

### Add Inventory

Creates an Inventory "Tank" to be monitored. Here you will Name your Inventory "Tank" and press Enter. Next will request your volume Unit of Measure and the Tank Capacity. Press Enter to create the Current Tank Level.

**\*\*Must be outside of a Shift to do this step\*\***

### Remove Inventory

Removes the Inventory Tank from being Monitored

**\*\*Must be outside of a Shift to do this step\*\***

## Inventory Settings

Inventory Access      Allows access to inventory outside of locked menu

Keypad Shortcut:      Pressing SHIFT + PRINT will allow you to Update, Fill, or Empty Inventory Levels quickly during a Shift

**\*\*After Adjusting the inventory you will be prompted to provide a Bill of Lading Number\*\***

**\*\*NOTE: After each calibration, you must reassign each product to its proper tank inventory.\*\***

## PRODUCT PRICES

Product Prices allows the price to be set for a specific product. For multiple products, pricing must also be changed. To set pricing, highlight the desired product and press ENTER. NOTE: if you have not changed the Product name, the factory default "DEMO" may be displayed.

**Unit Price** Highlight Unit Price and press ENTER. Input the price value and press ENTER.

**Tax 1 Name** Highlight Tax 1 Name and press ENTER. Input tax name and press ENTER.

**Tax 1 Type** Highlight Tax 1 Type and press ENTER. Use the navigation arrows to select Tax 1 Type and press ENTER.

**Tax 1 Value** Highlight Tax 1 Value and press ENTER. Input tax value and press ENTER.

None	No tax will be entered.
Percent	Tax amount value is calculated as a percent (%).
Per unit	Tax is calculated per unit of measure.
TaxTax	Tax is calculated on a tax.

**Tax 2 Name** Highlight Tax 2 Name and press ENTER. Input tax name and press ENTER.

**Tax 2 Type** Highlight Tax 2 Type and press ENTER. Use the navigation arrows to select Tax 2 Type and press ENTER.

**Tax 2 Value** Highlight Tax 2 Value and press ENTER. Input tax value and press ENTER.

None	No tax will be entered.
Percent	Tax amount value is calculated as a percent (%).
Per unit	Tax is calculated per unit of measure.
TaxTax	Tax is calculated on a tax.

**Currency** Select the Currency Symbol or Abbreviation and press ENTER

SYMBOL	
NONE	
\$	Dollar
£	Pound
¥	Yen
Rp	Rupee

ABBREVIATION	
NONE	
USD	US Dollar
EUR	EU Euro
A\$	Australian Dollar
AU\$	Australian Dollar
AUD	Australian Dollar
AED	United Arab Emirates Dirham
BGN	Bulgarian Lev
CAD	Canadian Dollar
C\$	Canadian Dollar
CHF	Swiss Franc
CLP	Chilean Peso
CZK	Czech Republic Koruna
DKK	Danish Krone
GBP	British Pound Sterling
HUF	Hungarian Forint
JPY	Japanese Yen

ABBREVIATION	
LTL	Lithuanian Litas
LVL	Latvian Lats
MN	Mexican Peso
MXN	Mexican Peso
MX\$	Mexican Peso
\$MN	Mexican Peso
M\$N	Mexican Peso
MN\$	Mexican Peso
NGN	Nigerian Naira
NZ\$	New Zealand Dollar
PLN	Polish Zloty
RON	Romanian Leu
SEK	Swedish Krona
VND	Vietnamese Dong
IDR	Indonesian Rupiah
INR	Indian Rupee

**Preview Pricing** Preview Pricing will show the Product price and taxes.

---

## ACTIVATE PRODUCT

Activate Product allows you to activate a product for a specific Shift. When liquid in your tank changes, you can change the product and calibration to match.

- To Activate a product, highlight the product and press ENTER.

## DEACTIVATE PRODUCT

Deactivate Product allows you to deactivate an active Shift product. When liquid in your tank changes, you can also change the product.

## PRODUCT PARAMETERS

Product Timing allows auxiliary device settings to be changed to suite the needs of the application. Currently set up for Product Density, Preset Valve, Air Eliminator Hold and Startup Volume. Also allows to preview and print the product parameters. Product Timing is product specific, adjusting the actuation or closure type.

<b>Product Density</b>	Select the Product to enter the density value if there is no densitometer. This will manually calculate the value of your Mass delivery.
<b>Flow Parameters</b>	Allows adjustment of specific flow settings for the product that are usually behind the W&M Menu.
Maximum Flowrate	Set the Max Flowrate of the selected Product
S2 Flowrate	Set Flowrate for S2 Valve operation
S1 -> S2 Closing Delay	Set closure rate for transition of S1 to S2
<b>Preset Parameters</b>	Preset Timing adjusts the valve closure type for preset or security valves. Highlight the Preset Timing function desired and press ENTER. This will be chosen as your default setting for the specific Product.
Preset Type	Select the kind of Preset the system should run from the below options.
<b>Automatic Presets</b>	
<i>Full-Auto</i>	Full Automatic tune preset shutoff for Solenoid S1 (fast) and S2 (slow) flow valves. Great for presets with varying system pressures. NOTE: Solenoid S1 (fast) flow closure is 10% of average flow rate.
<i>Semi-Auto</i>	Semi-Automatic tuned preset shutoff for Solenoid S2 (slow) flow valve. Highlight Semi Auto and press ENTER. Input Solenoid S1 (fast) flow valve closure and press ENTER.
<b>Fixed Presets</b>	
<i>Next Fix</i>	Next Fix is an automatic tune shutoff, however it will allow the preset to overrun batch amount. Designed to automatically correct the shutoff on the next preset delivery. Highlight Next Fix and press ENTER. Input Solenoid S1 (fast) flow valve closure and press ENTER.
<i>Static</i>	Static settings for the Solenoid S1 (fast) and S2 (slow) flow valves. There is no automatic correction for zero point shutoff. Highlight Static and press ENTER. Input Solenoid S1 (fast) flow valve closure and Solenoid S2 (slow) flow valve Values and press ENTER. NOTE: for Solenoid S2 (slow) flow valve timing, run a separate preset batch with the S2 at Zero. What volume is over run and read on the screen after the shutoff should be input into the S2 (slow) valve timing.

<b>Preset Parameters</b>	Allows changes to the following settings that affect any Preset transactions run on the TCS 3000.
<i>Dwell Volume</i>	Remaining preset volume to begin S1 Valve Closure
<i>S1 Close Volume</i>	Remaining Preset Volume between S1 turning off and fully closing <b>(only available when Full Auto is selected)</b>
<i>S2 Check Point</i>	Point in the Dwell Volume where the S2 Close Volume is measured. Defined as a percentage of the given Dwell Volume. Available between 50% - 90%. <b>(only available when Full Auto and Semi Auto are selected)</b>
	<b>Full Auto</b> Percent between when S1 Valve is closed and the end of the delivery (Default 50%)
	<b>Semi Auto</b> Percent between the beginning of the Dwell Volume and end of the Delivery (Default 50%)
<i>S2 Close Volume</i>	Volume that will pass through the system between switching off S2 and flow completely stopping
<i>Flow Parameters</i>	Same menu as on page 37
<b>Air Eliminator Hold</b>	When the TCS 3000 senses air, the Solenoid S1 and S2 preset relays will de-energize for closure and energize the Auxiliary Relay open for the exhaust port to remove air from the system. Highlight Air Eliminator Hold and press Enter. The HOLD (s) is the adjustable setting for the Auxiliary Relay closure in Seconds. Input value in Seconds and press ENTER.
<b>Startup Volume</b>	Is a soft-start mechanism at the beginning of a delivery through which the S1 fast flow valve will stay closed for scalable time (Seconds). Startup Volume will work with either the Valve Type 1101 or 1001 valve actuation.
<b>Pump Control &amp; Timing</b>	<p><u>Enable/Disable Pump Control</u> and select ENTER.</p> <ul style="list-style-type: none"> <li>- Pump is an Optional Output Control</li> <li>- Enabled means that the pump control output to energize a PTO or Hydraulic Drive during a truck delivery.</li> <li>- Disabled means that the pump control is not active and will not energize.</li> </ul> <p><u>Pump Speed Control 1</u> is a solid state voltage output signal based on a flow rate setting. Flow rate setting of zero (0) is disabled. Utilizes the Pump Starter terminal. <i>NOTE: Pump Speed Control overwrites the Additive Pump setting.</i></p> <p><u>Pump Speed Control 2</u> is a solid state voltage output signal based on a flow rate setting. Utilizes the Reset terminal. Flow rate setting of zero (0) is disabled.</p> <p>**NOTE: This is the same setting(s) as listed on page 22**</p>
<b>Preview Prod Params</b>	Preview the product parameters by pressing ENTER, then scroll through each page to see what values are selected for each parameter.
<b>Print Product Params</b>	Print the product parameters by pressing ENTER if a printer is enabled. All values will be printed for each parameter for review.

## AUXILIARY SETTINGS

Adjust the settings of the auxiliary sensors by first selecting the product the sensor is being used with. It is necessary to program the L1 Password and Access Key before the use of these auxiliary settings. The limit actuation will lock an operator out of further deliveries until the Access Key is provided. System Line 1, 2 and 3 will display error on the delivery ticket.

### Additive Injector

Allows you to change the Additive Injector Type or change all Additive Injector Settings

NOTE: This is menu dependent on the access setting being enabled (see page 34). If Config Settings is ENABLED

**\*\* PLEASE REVIEW PAGES 25-26 TO SEE MENU OPTIONS FOR ADDITIVE INJECTOR \*\***

None	No Injector
External	A constant positive signal output is provided during product delivery. NOTE: External additive injector controls injection pump ratio and frequency.
Piston -	A pulsing positive signal output is provided during product delivery. NOTE: TCS 3000 controls the Piston Additive Injector Pump.
Pressure	A constant positive signal output is provided to control an additive injection pump with a additive flow meter and a control valve to maintain the target PPM concentration.

### Pressure Sensor

Select with Sensor Address you wish to be active (dependent on which analog communication board selected in the System Settings). Only one can be chosen for the Differential Pressure Sensor. When the Sensor Address is selected, only then will the Minimum and Maximum CDP, and Max ACH. Flow Rate appear. Uncorrected (Measured) Differential Pressure should be calibrated prior to use.

Minimum CDP	Enter the minimum corrected differential pressure (CDP) value to prevent a delivery to continue if this CDP value is not achieved. If zero (0) is entered, this function will be disabled. NOTE: used for filter and hose bursts.
Maximum CDP	Enter the maximum corrected differential pressure (CDP) value to prevent a delivery to continue if this CDP value is exceeded. If zero (0) is entered, this function will be disabled.
Max ACH. Flowrate	Enter the maximum achievable flow rate for the delivery pumping system. Value is used for the Corrected Differential Pressure formula. <i>To read the <u>TRUE MEASURED DIFFERENTIAL PRESSURE</u>, enter a value of ZERO (0) to disable the Max Achievable Flow Rate.</i>

Differential Pressure is calculated from the Inlet and Outlet of a filter vessel. A pressure differential pressure sensor is required for this setting. The Corrected Differential Pressure is generally calculated with the following formula:

$$\frac{\text{MAXIMUM ACHIEVABLE FLOW RATE}}{\text{ACTUAL FLOW RATE}} \times \text{DIFFERENTIAL PRESSURE} = \text{CORRECTED DIFFERENTIAL PRESSURE}$$

Corrected Differential Pressure will illustrate the corrected value of the Inlet and Outlet pressure differential when Filter Vessel Systems are not being operated at maximum capacity.

### Water Sensor

Select Water Contamination Sensor and chose the Sensor Address you wish to be active (dependent on which analog communication board selected in the System Settings). When the Sensor Address is selected, only then will the Water Limits appear.

Water Limits	To set the Check (Alert), Alarm and Stop level, select Water Limits and press ENTER.
Stop Level	Enter the Stop Level value in parts per million (PPM) and press ENTER. - The Alarm TIME must be entered to JIG/A4A compliant. The Stop Level requirement is 5 seconds, in which the Stop Level must be achieved for this value to shut the delivery off. Press ENTER to continue.

<i>Alarm Level</i>	Enter the Alarm Level value in parts per million (PPM) and press ENTER.  - The Alarm TIME must be entered to JIG/A4A compliant. The Stop Level JIG requirement is 10 seconds, in which the Stop Level must be achieved for this value to shut the delivery off. Press ENTER to continue.
<i>Check (Alert) Level</i>	Enter the Alert Level value in parts per million (PPM) and press ENTER.  - For your convenience, a Check (Alert) TIME has been provided to hide the alert message screen and lamp indication for a specified time during a fueling operation. Enter time and press ENTER to continue.
<i>Start Delay</i>	Enter the Start Delay in seconds, then press ENTER. This feature will delay the water content reading for the Start Delay duration. Every time the flow rate stops, the Start Delay will be observed. The intention of this setting is to minimize the delivery startup spike in water content. NOTE: to disable the Start Delay feature, enter zero (0) and press ENTER.
<i>Min Flowrate</i>	Enter the Minimum Flow Rate, then press Enter. This feature will ignore the water content reading below the set Minimum Flow Rate. The intention of this setting is to minimize the cavitation spike represented in water content at the close of a delivery. NOTE: to disable the Minimum Flowrate feature, enter zero (0) and press ENTER.

**Density Sensor**

Select Densitometer Sensor and chose the Sensor Address you wish to be active (dependent on which analog communication board selected in the System Settings. When the Sensor Address is selected, only then will the Density Limits appear.

Density Limits	To set the Minimum and Peak Stop, Minimum and Peak Warning Limits, select Density Limits and press ENTER.
<i>Peak Stop Limit</i>	Enter the Peak Stop Limit value in the unit of measure chosen and press ENTER. The Peak Stop Limit will stop the delivery if this value is achieved. If zero (0) is entered, you will disable the Stop limit.
<i>Peak Warning Limit</i>	Enter the Peak Warning Limit value in the unit of measure chosen and press ENTER. If zero (0) is entered, you will disable the Warning limit.
<i>Min Stop Limit</i>	Enter the Minimum Stop Limit value in the unit of measure chosen and press ENTER. The Minimum Stop Limit will stop the delivery if this value is achieved. If zero (0) is entered, you will disable the Stop Limit.
<i>Min Warning Limit</i>	Enter the Minimum Warning Limit value in the unit of measure chosen and press ENTER. If zero (0) is entered, you will disable the Warning limit.

**PROUCT LISTS**

Displays a list of Active, Inactive and Un-Calibrated products on the TCS 3000. To view these Products, highlight the selection and press ENTER.

---

## USERS ID MANAGEMENT

The Users ID Management is a program to manage User Access, Consortium Management, Fleet Fueling or Asset Management. There are six (6) Customer Identification Databases. When a new record is created, you must Enable the Validation of the corresponding Customer ID number under the Delivery Settings.

NOTE: the Users ID Management feature will not be visible from the System Menu until the MR1 system mode is Enabled in the System Settings. MUST enter L2 Password to access menu (see page 19).

### USR\_DB# (1 - 6)

<i>Number of Records</i>	Identifies the number of existing records for each associated database
<i>Add/Edit ID</i>	<ol style="list-style-type: none"><li>1) Enter an Alpha Numeric pin identification code for the Manual Entry</li><li>2) Enter the user identification (Asset, Employee, Company, etc) for the User Friendly Name.</li><li>3) Enter YES or NO if a radio frequency identification (RFID) tag &amp; reader. NOTE: See page 15 for required external RFID readers</li></ol> <p>YES Place the RFID tag in a location that the reader can be identified. Once read, the display will show you the RFID identification code, then press Enter to accept. You will then need to put an expiration period on the User ID record. Enter the date and time via Year, Month, Day, Hour, Minute (YYYY.MM.DD.HH.MM). When complete, press Enter and then Mode to save the record.</p> <p>NO Enter the expiration period on the User ID record. Enter the date and time via Year, Month, Day, Hour, Minute (YYYY.MM.DD.HH.MM). When complete, press Enter and then Mode to save the record.</p>
<i>Remove ID</i>	To remove the User ID record, enter the record number. The database will display the record details and ask you to press Mode to confirm deletion or Cancel to Abort the deletion process.

## Advanced Functions

**Lock the System** Enter Access Key to lock the TCS 3000 register from local use. This feature is only available for remote computers (i.e. handhelds, tablets, mobile phones, etc.).

*\*\* Press Shift + Mode + Enter to put in your Access Key to bypass \*\**

**System Shutdown** System Shutdown Shuts the TCS3000 down. You must power down to the TCS 3000 and reboot to turn the unit back on.

## System Update

System Update allows you to upgrade the TCS 3000 Software. NOTE: Update process does NOT change Weights & Measures settings or parameters.

Procedure to upload new software is as follows:

- 1) Load new software upgrade to an empty/blank USB thumb drive (dongle). Specifications for the USB thumb drive should be 8 Gigabytes and formatted to FAT 32.

NOTE: The new software upgrade should be the ONLY file on the drive.

- 2) Plug the USB thumb drive (dongle) into the USB3.0 port. See Figure 1 on following page..
- 3) Under Advanced Functions, locate System Update and press ENTER.
- 4) The screen will display System Update, press MODE to continue with the update.
- 5) If the thumb drive is not recognized or there is a faulty cable, the display will respond with NO UPDATE DATA error message.
- 6) Once the file is recognized, the operating system will begin the update process. This should take approximately 45 seconds.  
NOTE: Do not power down or pull USB thumb drive until the TCS3000 tells you to do so.
- 7) You may remove the USB and close the TCS 3000 register once the Update is Complete.

**Service Menu** Allows testing out the outputs relays for the TCS 3000

### Hardware Tests

<i>Pump_Control</i>	Turn on output for Pump Control
<i>Injector_Pump</i>	Turn on output for Injector Pump
<i>Aux_1</i>	Turn on output for Aux 1
<i>Aux_3</i>	Turn on output for Aux 3

## System Logs

Allows the exporting of the logs held inside the TCS 3000 to a connected USB drive

### Export System Logs

Export system generated logs to an empty FAT 32 formatted USB drive

## Export Tickets

Allows the exporting of tickets held inside the TCS 3000 to an empty FAT 32 formatted USB drive

**\*\*NOTE:** Exporting tickets to USB will provide the option to move the exported tickets from the Non-Transferred to the Transferred folder on the TCS 3000.\*\*

Export All	Export all tickets from the 3000
Export Delivery	Export only delivery tickets
Export Shift	Export only shift tickets
Export Prover	Export only prover tickets
Export Inv.	Export only inventory tickets

## Export Ticket Config

Setting allows a customer to copy a configured ticket from one register and transfer it to another register without having to reprogram ticket.

Procedure to copy and transfer configured ticket:

- 1) Insert an empty/blank USB thumb drive (dongle) into port labeled USB 3.0. Specifications for the USB thumb drive should be 8 Gigabytes and formatted to FAT 32.

NOTE: Only copy ticket config to empty/blank USB thumb drive.

- 2) In Advanced Functions, navigate down to Export Ticket Config and press Enter. See Figure 1 below. The current ticket configuration will be copied to the USB thumb drive (dongle). When the screen displays CONFIGURATION EXPORTED, you can remove the USB from the register and press any key to continue.
- 3) Plug the USB into the USB 3.0 port on the TCS 3000 register you wish to upload the ticket configuration.
- 4) Under Advanced Functions, locate System Update and press ENTER.
- 5) The screen will immediately say Update Found, please remove the media now.
- 6) If the thumb drive is not recognized, the display will respond with NO UPDATE DATA error message.
- 7) Once the file is recognized, the operating system will begin the update process. This should take approximately 45 seconds.  
NOTE: Do not power down during the update process.

FIGURE 1

USB 3.0

Ethernet

SIM Card

CR24477N Battery

Mini USB 0

Mini USB 1



# Installation Procedure — Daisy Chain

## Daisy Chain:

Daisy Chain is used for linking multiple registers together to use one printer or to link multiple registers to the data-base.



To Daisy Chain the Registers use a two wire 22 gauge shielded cable. Nominate one Register to be the Host.

Once you've chosen which Register will be the Host the other Registers will be considered the clients. Strip a small amount of wire and run the wire from slot A and B of DAISY CHAIN on the Host Unit to slot A and B of DAISY CHAIN on the Client Unit.

To tie the Client to the next Client unit on the Daisy Chain, strip a small amount of wire and run the wire from slot A and B of DAISY CHAIN to slot A and B of the next client's DAISY CHAIN.



Host

Client 2

Client 3

Client 4

The Host will have 2 wires.

Client 2 will have 4 wires.

Client 3 will have 4 wires.

The Last Client will have 2 wires.



Continue to Daisy Chain until you have tied the chain together, alternating slots on the Daisy Chain until you've reached the end of the chain. The Host and the last Client on the chain will be the only two registers on the chain to have a one wire connection.

---

## Daisy Chain for the Printer

Connect the Printer to the Host Register. To set the Host :

Enable the Printer:

SYSTEM MENU → SYSTEM SETTINGS → PRINTER SETTINGS → ENABLE/DISABLE PRINTER → ENABLE PRINTER

Select the Printer:

PRINTER SETTINGS → SELECT PRINTER → [SELECTED PRINTER] → ENABLE

### Selecting the Host Register

Select Register as Host:

PRINTER SETTINGS → DISABLE/ENABLE HOST → ENABLE

Select the Client Range:

PRINTER SETTINGS → PRINTER HOST → CLIENTS ADDRESS RANGE → CLIENTS RANGE START ADDRESS [ Enter 2 and Select] →

CLIENTS RANGE END ADDRESS [ Enter the number of Registers on the Chain and Select]

**\*Please Note the Host is always # 1. The Client always starts at #2\***

### Selecting the Client Register

**\*If you are not using the Daisy Chain for the Printer Please Disregard the Enabling and Selecting the Printer Steps.**

Enable the Printer:\*

PRINTER SETTINGS → ENABLE/DISABLE PRINTER → ENABLE PRINTER

Select the Printer:\*

PRINTER SETTINGS → SELECT PRINTER → [REMOTE] → ENABLE

SYSTEM SETTINGS → CONNECTIVITY SETTINGS → NETWORK SETTINGS → ADDRESS → DEVICE ADDRESS [Select the number of the unit you are using ex. 2 if it is the second register on the chain or 3 if it's the third register on the chain.]

To Connect to the Chain:

SYSTEM SETTINGS → CONNECTIVITY SETTINGS → NETWORK SETTINGS → INTERFACE BRIDGE [Only used when there are 2 Registers tied in the chain] → TRANSFER DATA BETWEEN RS232 <-> RS485 INTERFACES ENABLED

Continue the Selecting Client Register steps for every Client on the Chain.

**\*Please note, you must End Shift before you may Add or Remove Inventory\***

Real Time Inventory is for Automatic Tank Levels Only

### Add Inventory:

While holding Shift select Mode → System Menu → Product Settings → Inventory → Add Inventory → GIVE INVENTORY NAME (Use the Keypad to assign a name, ex. Av Gas, Gasoline, Tank 1, Tank 2, etc.) → Select Unit Volume (Gallons, Liters) → ENTER CAPACITY (Tank Size) → ENTER INVENTORY (Actual Known Inventory) → Press Any Key to Continue

### Assign Inventory:

**Assign Inventory** → Select an Active Product → Assign the Active Product to an Inventory List → Press Any Key to Continue

\*Please Note You can apply multiple inventories to one meter.\*

### Update Inventory:

**Update Inventory** → Level Meter → Select CH# (Ex. If Product 1 is tied to CH2, then you select LVL2) →

**Inventory Update Message** → Press Any Key to Continue

\*Please Note: Use CH2-6\*

\*Also Note: Level Meter will only update when there is no movement.\*

### To Check the Changes:

**Update Inventory** → Level Meter → The LVL# you selected should be highlighted.

\*If you enter into this screen and None is highlighted, then the unit does not see the circuit board or the Level Gauge.

A ticket will generate if a printer is set up.

### Remove Inventory:

**Remove Inventory** → Select Inventory → Press Mode to Confirm

### Print Inventory Report:

**View Inventory** → Print Inventory Report

### Bill of Lading:

Once you have finished in Inventory, select STOP/CANCEL →

ENTER BILL Nr. → START/ENTER

### Add Inventory:

While holding Shift select Mode → System Menu → Product Settings → Inventory → Add Inventory → GIVE INVENTORY NAME (Use the Keypad to assign a name, ex. Av Gas, Gasoline, etc.) → Select Unit Volume (Gallons, Liters) → ENTER CAPACITY (Tank Size) → ENTER INVENTORY (Actual Known Inventory) → Press Any Key to Continue

### Assign Inventory:

**Assign Inventory** → Select an Active Product → Assign the Active Product to an Inventory List → Press Any Key to Continue

\*Please Note You can apply multiple inventories to one meter.\*

### Update Inventory:

**Update Inventory** → ADD To Inventory → ENTER AMOUNT (Amount added to tank)

**Set Inventory Value** → ENTER CURRENT VALUE (Current amount of product in the tank)

**Fill Up Inventory** → Press Any Key to Continue (Resets Inventory to full capacity)

**Empty Inventory** → Press Any Key to Continue (Zero's out tank amount)

### Remove Inventory:

**Remove Inventory** → Select Inventory → Press Mode to Confirm

### Print Inventory Report:

**View Inventory** → Print Inventory Report

### Bill of Lading:

Once you have finished in Inventory, select STOP/CANCEL →

ENTER BILL Nr. → START/ENTER

### Inventory Short Cut

In the Delivery Screen:

**Hold down SHIFT and select PRINT (while holding Shift)**

You can enter inventory through the short cut only after you've set up and assigned inventory.

**Color Guide: Blue: Operating Volume**

**Yellow: 25% Cautionary Volume**

**Red: 10% Low Volume**

## TEMPERATURE PROBE CALIBRATION HOW TO

\* The following is based on product(s) you have calibrated. You must select the compensation table and the temperature unit for the product when Calibrating your product in order to Calibrate Temperature.\*

Press Shift and Mode to enter the Select Function Screen.

Use the arrow keys to highlight SYSTEM MENU and Select START/ENTER.

\*Remove the Calibration Bolt and set in a safe location.\*

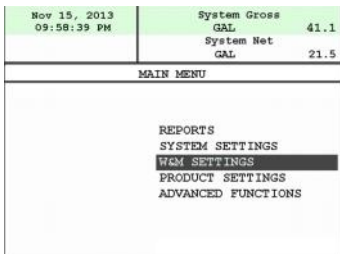

Use the arrow keys to highlight W&M SETTING. Select START/ENTER.

Use the arrow keys to highlight your product. Select START/ENTER.

Use the arrow keys to highlight PRODUCT TEST RUN. Select START/ENTER.

Use the arrow keys to highlight your product. Select START/ENTER.

Use the arrow keys to highlight TEMP PROBE select START/ENTER.

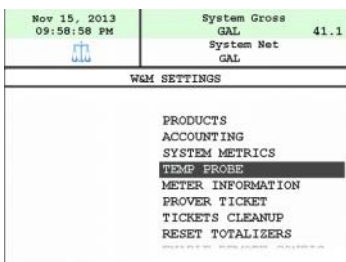

Selecting TEMP PROBE will take you to Offset Calibration  
Press START/ENTER  
(You are now calibrating the TCS3000 Register Temperature Probe to the Weights and Measures Temperature Probe)

Use the arrow keys to highlight the Reference Temperature select START/ENTER.

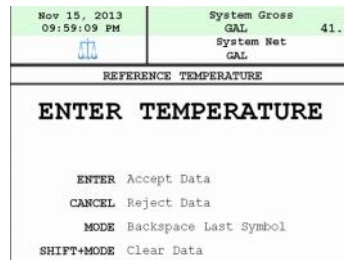
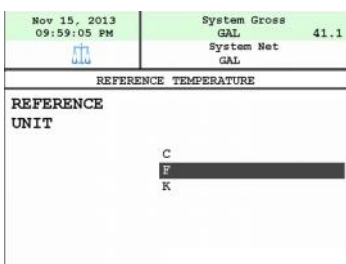

\*Note: You will want to take 3 temperature readings during a run to get the average temperature.



Enter the Average Temperature Select START/ENTER

\*Note: The register will display that it is calibrating and is applying the corrections. It will take a minute to calibrate the RTD Probe to the Weights & Measures Probe.

When Calibration is done the Register will display the following message:

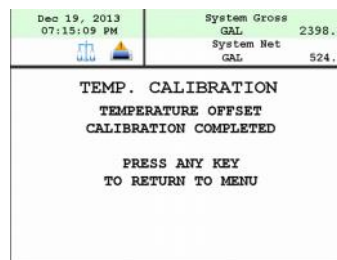

Repeat the steps if necessary.

# Troubleshooting

The TCS3000 troubleshooting guide covers most common problem situations. Call your Total Controls Service Center for any problems that are not covered in this guide.

NOTICE	DANGER
It may be necessary to break Weights & Measure seals to perform certain troubleshooting steps in this guide. Contact your supervisor or local Weights & Measures authorities for information before breaking any seals.	Serious Injury or Death may Result – Fire, Explosion, and Electrical Shock Hazard.  Only trained and authorized personnel should perform troubleshooting. Use extreme caution when troubleshooting and taking all electrical measurements. Be sure that equipment is in a well ventilated area and that hazardous or flammable vapors are not and will not be present during testing. If equipment is located in a hazardous environment, it may be necessary to remove the equipment and perform troubleshooting in a safe area.

**TOOLS/MATERIALS:**

- #2, #3 and #5 Metric Allen Wrenches
- 7/16", 1/2" and 1-1/8" Wrenches
- Digital Multimeter
- 8G Thumb Drive (FAT 32) and possibly a TCS USB Adapter
- Wire Stripper
- RTV Silicone
- Electrical Tape/Heat Shrink

## Troubleshooting Guidelines:

1. Before attempting to troubleshoot the TCS3000 system, become familiar with the operation and set-up of the specific installation.
2. Make sure all electrical connections are secure and tight.
3. Make sure all terminal blocks are firmly connected.
4. ALWAYS use a good digital multimeter. Voltage levels are critical to proper system operation. Use an accurate, reliable multimeter to test for proper voltages at the start of any service procedure. Voltage requirements are listed under each component.













NOTE: Check for proper operating voltages before changing the circuit board. If the circuit board needs to be changed, be sure to remove all power to the TCS3000.

5. NEVER remove a terminal block or jumper with the power on.
6. NEVER install a terminal block or jumper with the power on.
7. NEVER force a terminal block into its location.
8. NEVER exchange or reposition terminal blocks on the circuit board.
9. In case of a major problem such as a burned or water-damaged circuit board, evaluate possible causes before replacing it and turn the power back on.
10. Isolate the problem before changing the circuit board.
11. Return faulty circuit boards with the proper RMA forms, concisely completed.

There may be several probable causes for a system malfunction. The following list are several probable causes to aid in returning the system to operation as quickly as possible. Should you require contact with Total Control Systems factory support, please provide the following information to help manage the problem.

- REPORTS: Shift + Mode -> System Menu -> Reports
- 1) TCS 3000 Serial Number under Meter Information
  - 2) Software and Firmware under Version Information
  - 3) Print Prover Ticket before any changes are made to system settings.
  - 4) Print System Parameters

## BASIC DISPLAY ICON INDICATION

ICON	INDICATION	SOLUTION
	Printer is connected with paper	Printer is Enabled, connected and with paper. Awaiting delivery.
	Printer is out of paper	Printer Enabled, connected, but without paper.
	No printer connection	Printer has no communication with TCS Register Check cable for damage Epson printer DIP switch should be on 3 Power supply fuse is blown
	Valve or Pump not open in Delivery	Valve or Pump are closed within delivery. Pump Starter delay timing can be adjusted under W&M Settings.
	Active delivery	Valve or Pump Enabled
	Multiple Tank Delivery	Multiple Tank Delivery is Enabled and begun by pressing Shift + Start
	You're in System Settings Screen	Exit out and go to the Delivery Screen
	You're in Weights & Measure Settings	Only shows when in W&M Settings. To remove, make sure the calibration screw on the register is screwed in.
<b>AIR</b>	Air is present in system or level sensor is low or high	The Air Eliminator Detection is Enabled.
	Density is out of range	The Density reading is outside the limit entered values
	Water is out of range	Water PPM reading is outside the limit entered values
	WIFI / Cellular Modem	Connection to the WIFI or Cellular network
	WIFI Access Point	Connection to the WIFI Access Point
	Ethernet Connection	Connection to the Local Area Network

We will categorize Troubleshooting with HARDWARE/SOFTWARE, SYSTEM, WEIGHTS & MEASURES and PRODUCT Settings in the TCS 3000 Register. TCS HUB and Modem Settings follow register troubleshooting. The list is not all-inclusive and should only be used as a guide.

### HARDWARE/SOFTWARE TROUBLESHOOTING

PROBLEM	PROBABLE CAUSE	SOLUTION
Unit will not power up or there is no display.	Inadequate supply voltage, +9 to 28VDC are required for operation.  Ground short on terminals, wire harness or lug.	<ol style="list-style-type: none"> <li>1. With the key in the accessory position, check the battery voltage to the circuit board. Use the negative terminal as DC ground. While the TCS3000 will power-up at +9VDC, it is recommended that the input be at least +12.6VDC.</li> <li>2. There is a ground short within the register or on the cable harness. Check wiring on grounds in register or chassis. Some ground shorts come from a cable jacket being worn through with a tie-down.</li> <li>3. Check the 7.5A, in-line fuse for continuity. It is located in the accessory power line. Replace if necessary.</li> <li>4. If the green light blinks fast it is doing what it is supposed to, but then it will go to a slow blink. If you see red, then you do not have enough power on the register. It must see a minimum of 9vdc.</li> <li>5. If the red light comes on and the unit doesn't power-up. Check the voltage if the voltage is OK but the temperature is -20 F this will indicate that the heater is warming the display to prevent any damage to the VGA display and should come-up shortly.</li> </ol>

## HARDWARE/SOFTWARE TROUBLESHOOTING (CONTINUED)

PROBLEM	PROBABLE CAUSE	SOLUTION
Unit blows 4A fuse.	+12VDC Battery line is shorted to ground.	<ol style="list-style-type: none"> <li>1. For safety reasons, remove the 4A, in-line fuse from the accessory power cable.</li> <li>2. Unscrew the 3 pin power connector. Inspect for stray wire strands and visible shorts.</li> <li>3. Inspect the full length of the power cable. Look for damaged insulation, which may cause shorting between the cable and ground potential (e.g. truck frame or chassis). If the power cable is damaged, it must be replaced.</li> <li>4. Replace the 4A fuse and re-install the wires into the terminal Bd. connector.</li> <li>5. If the 4A blows again, then replace the power cable.</li> <li>6. If the 4A fuse blows after replacing the power cable, then replace the TCS3000 terminal circuit board.</li> </ol>
Display is reading in reverse	Pulse Channel TAHA1 and TAHB1 are wired backwards	Switch Pulser wiring between Channel A and B. You can also change the pulser direction inside W&M as well.
Black display screen but power LED indicator is on.	Sufficient power to the register, however there may be a current draw from the system that will not allow the register display to power up properly.	<ol style="list-style-type: none"> <li>1. Cycle power of the register</li> <li>2. Allow diesel chassis glow plugs to properly charge before turning over the ignition.</li> <li>3. Power On Time Relay may be required for installation.</li> <li>4. Contact factory for further support.</li> </ol>
Time and Date reset	Low Battery Power  Short on Battery	<ol style="list-style-type: none"> <li>1. Go to Operation Status under Reports and check internal battery voltage. If under 2.75V, battery must be replaced.</li> <li>2. Check that no wires are in contact with Battery. Time and Date are reset if in contact and power is shutoff. Use electrical tape or heat shrink on bare wire to prevent from happening again.</li> <li>3. If time and date reset each time you cycle power, change Time Source from Controller to BIOS in Regional Settings.</li> </ol>
Display screen has multiple colored lines.	Ribbon cable is not seated properly.	<ol style="list-style-type: none"> <li>1. Contact factory for further support.</li> <li>2. Disassemble the front cover of the register to reseal the display ribbon cable.</li> </ol>
Buttons on my keyboard are not active.	Tactile button has been damaged.	<ol style="list-style-type: none"> <li>1. Contact factory for further support.</li> <li>2. Disassemble the front cover of the register to replace keyboard.</li> </ol>
System One Error	New Software not compatible with existing Firmware	<ol style="list-style-type: none"> <li>1. Press STOP/CANCEL to back out of a level and continue with normal operation of the register. This code detects software features that not compatible with existing firmware.</li> <li>2. Some functions will not operate (Additive Injection, Differential Pressure, etc.) under old Firmware.</li> <li>3. Contact factory for Firmware upgrade.</li> </ol>
Register reboots in Idle or Delivery	Ground Short	<ol style="list-style-type: none"> <li>1. Loose ground wire causing short. Check power distribution box and TCS 3000 register for loose grounds. Find and tighten.</li> <li>2. Inadequate power due to current draw from hose reel or solenoid coil.</li> </ol>
Operating System (OS) Error Controller Com Error Grub Error Root Password Error	OS loading error during boot up	<ol style="list-style-type: none"> <li>1. OS loading errors occur during startup. Voltage spikes or current draws during OS bootup can corrupt software.</li> <li>2. Contact factory for replacement.</li> </ol>

## SYSTEM SETTINGS TROUBLESHOOTING

PROBLEM	PROBABLE CAUSE	SOLUTION
Display screen is incorrect	Default display is chosen	<ol style="list-style-type: none"> <li>1. If a different display screen is shown, it's possible the customer pushed Mode to flip to a different display screen than the Default screen.</li> <li>2. If a different display screen is shown during a delivery, then the Default display screen must be changed. See Display Settings under System Settings for correction.</li> </ol>
Display is too dim, or too bright	Display brightness was not adjusted for current environment	<ol style="list-style-type: none"> <li>1. The Brightness can be adjusted from 30% to 100%.</li> <li>2. There is no "Sleep" mode.</li> </ol>
Daisy chain communication is not working	<p>Network Address of registers are not in proper sequence</p> <p>Printer Host and Client Addresses are not in proper sequence</p>	<ol style="list-style-type: none"> <li>1. Check the RX and TX wiring between registers.</li> <li>2. Make sure the printer is wired to the primary HOST register.</li> <li>3. Check the Device Addresses of each register, with the primary HOST as 1 and Clients 2 to 8.</li> <li>4. Make sure the primary HOST register has the Client Address Range set to communicate with all the TCS 3000 registers in the daisy chain.</li> <li>5. Client addresses must have REMOTE PRINTER selected to be able to print delivery tickets. NOTE: Remote Printer has no effect on wireless data transfer.</li> </ol>
Delivery Not Completed	Previous delivery ticket was not printed	<ol style="list-style-type: none"> <li>1. Press Print to print previous ticket.</li> <li>2. Keep Master Switch on until delivery ticket has printed.</li> <li>3. Make sure the correct printer is selected.</li> <li>4. Make sure TCS 3000 address is correct for each register.</li> <li>5. Check power and communication cables for proper connection or damage.</li> <li>6. On initial use of Epson printer, you must cycle power on printer after #3 dip switch is turned on.</li> <li>7. Printer Error light is flashing. If rebooting the printer does not eliminate the error light, printer must be replaced.</li> <li>8. If printer or cable connection is damaged, you must replace. Disable printer and continue use.</li> </ol>
Epson printer release light flashes.	Low voltage to the Epson printer.	<ol style="list-style-type: none"> <li>1. Check the battery voltage for a minimum of +12.6VDC.</li> <li>2. Under extreme cold conditions, the printer may not operate. Warm up the cab of the vehicle.</li> <li>3. If the release light continues to flash, replace the Epson 295 Printer.</li> </ol>
No power indicator lights to the Epson printer.	No power to the Epson printer.	<ol style="list-style-type: none"> <li>1. Verify that the power switch is in the ON position. This switch is located on the left-hand side of the Epson 295 Printer.</li> <li>2. Verify that the printer power supply fuse is not blown.</li> <li>3. Check the printer power cable to ensure that it is seated properly. If the problem persists, replace the power cable followed by the Epson printer.</li> </ol>
Time and Date are incorrect	Time and Date were not configured to region	<ol style="list-style-type: none"> <li>1. Go Regional Settings to adjust time and date, as well as format.</li> <li>2. Set Time through the 24 hour clock, and be sure to use "Periods" between Hours:Minutes:Seconds</li> <li>3. There is no Daylight Time Zone adjustment.</li> <li>4. TCS HUB may be setup to sync with Register for time change.</li> </ol>
After preset, display shows a "Pause" and will not finish transaction.	Preset Top-Up or Delivery Pause is Enabled	<ol style="list-style-type: none"> <li>1. Go to Preset Settings and Disable Preset Top-Up.</li> <li>2. Go to Pause Options and select Allow Pause, then Disable.</li> </ol>

## SYSTEM SETTINGS TROUBLESHOOTING (CONTINUED)

PROBLEM	PROBABLE CAUSE	SOLUTION
The Delivery Prompts are incorrect	Customer ID options have not be configured	<ol style="list-style-type: none"> <li>1. Determine what questions must be asked and enter into Customer ID 1 to 6 text.</li> <li>2. If question does not show, make sure the Request is enabled.</li> <li>3. To make sure operator enters data into Customer ID 1 to 6, make sure Enforce is Enabled.</li> <li>4. Validation only works if a Database has been loaded. Contact TCS for further support.</li> </ol>
Display Precision is incorrect	Precision changed for calibration	<ol style="list-style-type: none"> <li>1. There are two places to change display precision:</li> <li>2. W&amp;M Settings under System Metrics</li> <li>3. System Settings under Delivery Settings</li> </ol>
Delivery ends during fueling	Delivery Timed Out	Under Delivery Settings, you must extend your Time Out setting from 180 or 600 seconds.
External Display is not reading	Red Lion or Tekkino Serial Display settings are not Enabled	<ol style="list-style-type: none"> <li>1. Go to Auxiliary Devices and Enable External Display.</li> <li>2. Choose what is to be displayed under Configure</li> <li>3. Pulse driven displays from Red Lion must be configured correct. Contact Red Lion for support.</li> </ol>
I lost my passwords	Passwords are not stored locally	Contact TCS for factory support.

## WEIGHTS & MEASURES SETTINGS TROUBLESHOOTING

PROBLEM	PROBABLE CAUSE	SOLUTION
Product has wrong Name	The Register was never calibrated	Go into W&M Settings and select product to change name or add new product, then calibrate the product.
Metered volume not the same as Delivered Volume	Product calibration factor was not properly entered for 2 <sup>nd</sup> product.	<ol style="list-style-type: none"> <li>1. Under W&amp;M Settings, read Product 1001 calibration factor and copy it to Product 1002 under Edit Product Calibration.</li> <li>2. Entering calibration factors under Product Parameters will require a physical calibration operation.</li> </ol>
When Product with Additive Pump is selected, I do not see or hear the Injector actuating.	<p>Additive Injector Pump is not Enabled for Product</p> <p>Injector Pump not primed or has leak</p>	<ol style="list-style-type: none"> <li>1. Go to Product Parameters of Product with the enabled Injector Pump, then make sure Additive Injector is on External or Piston.</li> <li>2. Check that pump wiring is terminated correctly on Pump Starter and not reading 9V. If reading 0 or 12V, check the solenoid coil on the Injector Pump.</li> <li>3. Look for leaking fitting on suction side of Injector Pump.</li> <li>4. Prime Injector Pump</li> </ol>
Ticket is not set up correctly	Ticket must be configured	<ol style="list-style-type: none"> <li>1. Go to Accounting and select Configure Ticket</li> <li>2. Adjust Ticket configuration by adding, removing or editing each line. See ticket setup in the TCS User's Guide for more information. (ONLY APPLIES TO NEW TICKETS)</li> </ol>
Customer contact information is missing from ticket	Customer contact information is not setup in Header or Footer	<ol style="list-style-type: none"> <li>1. Go to Accounting and select Configure Ticket.</li> <li>2. Header and Footer Defaults for customer contact information or messages can be entered here.</li> </ol>
Delivery ticket will not print	<p>Out of paper or printer not connected</p> <p>Missing Minimum Ticket</p>	<ol style="list-style-type: none"> <li>1. Load paper ticket and press Print.</li> <li>2. Check cable connection and termination of printer wiring for loose connection.</li> <li>3. Check for worn cable throughout chassis.</li> <li>4. Missing "Minimum" Ticket. Requires a copy from Existing Ticket and named Minimum.</li> </ol>

## WEIGHTS & MEASURES SETTINGS TROUBLESHOOTING (CONTINUED)

PROBLEM	PROBABLE CAUSE	SOLUTION
Preset Valve will not open.	Solenoids are inactive or inoperative. Foreign debris in system.	<ol style="list-style-type: none"> <li>1. Start a delivery and listen for the audible clicking sound from the solenoids.</li> <li>2. If there is an audible click from the solenoid (but still no flow), this may be an indication of a mechanical problem with the main valve or its associate components.</li> <li>3. If there is NO audible click form the solenoid, check the voltage to Pin + and 0V of terminal block <b>Solenoid 1</b>. While the TCS3000 is still in delivery, use a reliable multimeter to measure the following DC voltages on the circuit board. Use 0 pin as a ground or frame ground. <b>TERMINAL SOLENOID 1 for 2 VOLTAGE</b> 9.0 VDC with plug remove VDC (NO LOAD) 2.0 VDC with solenoid connected 12.0 VDC with the solenoid energized</li> <li>4. If the above voltages are correct, this may be an indication of a problem with the valve or its associated components.</li> <li>5. Check for pinched 50 pin communication cable in register.</li> <li>6. If the above voltage are NOT correct, replace the Solenoids and/or TCS3000 terminal board.</li> </ol>
Preset Valve doesn't shut off or pulsates	Valve was never set-up and calibrated.	<ol style="list-style-type: none"> <li>1. Valve settings by product are not correctly setup. Check the following W&amp;M -&gt; Product Settings for minimum values: - S1-S2 Delay should be 2 seconds or more. - S2 Delay should be 0.2 seconds or more. - Maximum Flow Rate should be at least the maximum flow rate of flow meter.</li> <li>2. Run full calibration, followed by Full Auto preset setting. Allow preset to run in its entirety. NOTE: S2 is set for 20% of preset value.</li> <li>3. If preset solenoids continue to click, double the Maximum Flow Rate within Product Parameters.</li> </ol>
Delivery does not begin at Zero	Hose Charge is set too high	Hose Charge under Product Parameters is set too high. Change accordingly. NOTE: Hose Charge can be disabled.
Maximum Pulser Error	Noise from truck is creating false pulse transmissions	<ol style="list-style-type: none"> <li>1. Make sure that pulser cable leads are foil wrapped with a shield drain</li> <li>2. Only terminate the shield drain to the TCS 3000 register, and not the Direct Mount Pulser.</li> <li>3. Change Maximum Pulser Error to maximum allowable error of 255.</li> <li>4. Direct Mount Pulser has a shunt for 5V and 9-30V, check that the shunt is on 5V</li> <li>5. Ferrite Coupling over pulse encoder cable.</li> <li>6. Insulate the TCS 3000 register from chassis and place ground to battery.</li> </ol>
Missing Pulse Channel Error	One pulse channel is missing from the Dual or Quadrature pulser setting or pulse encoder has failed.	<ol style="list-style-type: none"> <li>1. Check wiring of the A and B channel wiring on the TCS 3000 register for good termination.</li> <li>2. Direct Mount Pulser has two LED indications for each channel. If product is flowing and one of these is not lit, then we have a bad encoder and it needs changed.</li> <li>3. Direct Mount Pulser has a shunt for 5V and 9-30V, check that the shunt is on 5V</li> </ol>

## WEIGHTS & MEASURES SETTINGS TROUBLESHOOTING (CONTINUED)

PROBLEM	PROBABLE CAUSE	SOLUTION
Temperature Error	Open or shorted circuit between the RTD probe and the TCS3000.	<ol style="list-style-type: none"> <li>1. Check the RTD Probe and terminal block for continuity.</li> <li>2. RTD Probe requires 4 wire leads.</li> <li>3. Remove terminal block Temp Probe from the circuit board. On the terminal block, measure and record the resistance between the following pins: <u>PIN READING</u> Red to White 100 Ω ±20 ohms</li> <li>4. If the readings are not within the above tolerances, replace the RTD probe.</li> </ol>

## PRODUCT SETTINGS TROUBLESHOOTING

PROBLEM	PROBABLE CAUSE	SOLUTION
Inventory does not change	Active Products have not been assigned to Tank Identification.	<ol style="list-style-type: none"> <li>1. Go into Inventory under Product Settings and Assign Inventory. Select Active Product and then choose the Tank Identification it is to be assigned to.</li> <li>2. For multiple products, you must Assign each product to one or more Tank Identification.</li> </ol>
Inventory shows a negative	Manual Inventory needs to be reset  Live Inventory is not Enabled	<ol style="list-style-type: none"> <li>1. Go into Inventory under Product Settings and update Inventory. Select Tank Identification and go to Fill Up Inventory. This will reset Inventory to 100% capacity. NOTE: Shift + Print takes you Inventory List for quick reset.</li> <li>2. Go to Inventory List and then Update Inventory. Select Tank Identification and choose Level Meter. Select LVL1 for the single compartment tank.</li> </ol> <p>NOTE: You must have the Analog Input set to X1 or X8 CHANNEL Communication and CURRENT under System Settings/Aux Devices for Live Inventory to be correct.</p>
Cannot find the added New Product	Product is not Active	<ol style="list-style-type: none"> <li>1. End Shift and go to Product Settings.</li> <li>2. Select Activate Product and choose new product from list.</li> <li>3. Begin Shift</li> <li>4. Remove unwanted products either in W&amp;M Settings or disable unwanted product in Product Settings.</li> </ol> <p>NOTE: Products that have been calibrated may appear either as an Active or Inactive Product. The TCS 3000 must have at least 1 Active Product in order to Begin a Shift and Start a Delivery. Products may only be Activated or Deactivated after a Shift has Ended.</p>
Preset valves are cutting in and out (chatter) during delivery	Preset Timing needs to be configured	<ol style="list-style-type: none"> <li>1. Go to Product Timing and select Preset Timing.</li> <li>2. Select Product and Preset Timing to configure preset option.</li> <li>3. There are four preset timing functions for the fast flow (S1) and slow flow (S2) preset shut off. <i>Full Auto</i> – Automatically Tunes S1 and S2 Shutoff <i>Semi Auto</i> – S1 is scalable and S2 automatically shuts off. <i>Next Fix</i> – S1 &amp; S2 automatically correct the next preset delivery. <i>Static</i> – S1 &amp; S2 are scalable.</li> <li>4. To eliminate solenoid modulation, select Static and be sure to move S1 Fast Flow preset volume to 8 gallons or more. The S2 Slow Flow preset volume is near 0.1 gallons.</li> </ol>

## MODEM TROUBLESHOOTING

PROBLEM	PROBABLE CAUSE	SOLUTION
No transactions into the HUB	Communication wire not correct  Connections to modem are loose  Insufficient Power	<ol style="list-style-type: none"> <li>1. Check wiring in the TCS 3000 to be sure RX and TX wires are terminated and seated correctly.</li> <li>2. 9 pin communication cable connection is loose on the modem (radio or cell).</li> <li>3. Radio Modem communication cable's RED wire is not terminated into the 12VDC power source.</li> <li>4. Reset button on Radio Modem has been pressed. Contact factory for replacement.</li> <li>5. Cell Modem communication cable's RED wire is terminated into the 12VDC power source and not the provided power plug.</li> </ol>
I cannot determine if all transactions have been transmitted	Memory Status	Go to Memory Status under Reports to find delivery ticket status. If any number of tickets are in the Non-Transferred directory, we know there must be a communication or software failure.

### RADIO MODEM SETTINGS

#### DIP Switch Settings

- 1 = ON
- 2 = OFF
- 3 = OFF
- 4 = OFF
- 5 = ON
- 6 = OFF

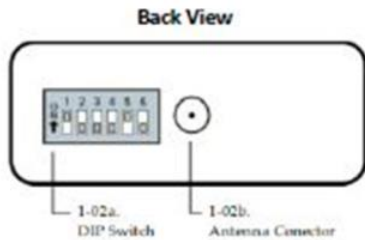

#### RSSI LEDs

(Green LED) indicates the amount of fade margin present in an active wireless link. Fade margin is defined as the difference between the incoming signal strength and the modem's receiver sensitivity.

- 3 LEDs ON = Very Strong Signal (> 30 dB fade Margin)
- 2 LEDs ON = Strong Signal (> 20 dB Fade Margin)
- 1 LED ON = Moderate Signal (> 10 dB Fade Margin)
- 0 LED ON = Weak Signal (< 10 dB Fade Margin)

Yellow light (Top) = DATA FROM OFFICE

Green light (Middle) = DATA TO OFFICE

Red light (Bottom) = POWER

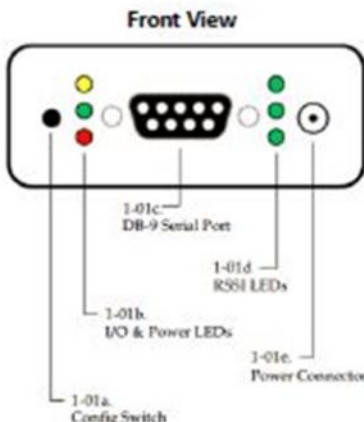

### CELLULAR MODEM SETTINGS

LED operation is as follows:

- Off—No Activity
- Green—Full Function
- Yellow—Limited Function
- Red—Not Functional

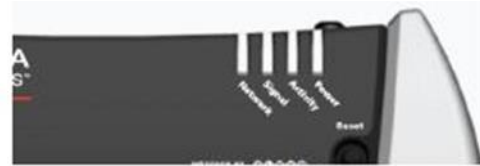

Network:

- Green—On the network
- Flashing Green—Roaming
- Yellow—Found service, attempting to connect
- Flashing Yellow—Link Down
- Red—No data connection available

SIGNAL:

Light shows the strength of the signal and may be nearly solid (strong signal) or flashing (weaker signal). A slow flash indicates a very weak signal.

ACTIVITY:

Pulse Green on packet transmit/receive on the radio link.

POWER:

- Off—No power (above 36V or below 7.5V)
- Red—System not operational
- Green—Normal operation
- Green, Occasional Yellow—GPS Lock
- Yellow—Low power mode or system rebooting

## TCS 3000 PARTS LIST (Generation 2)

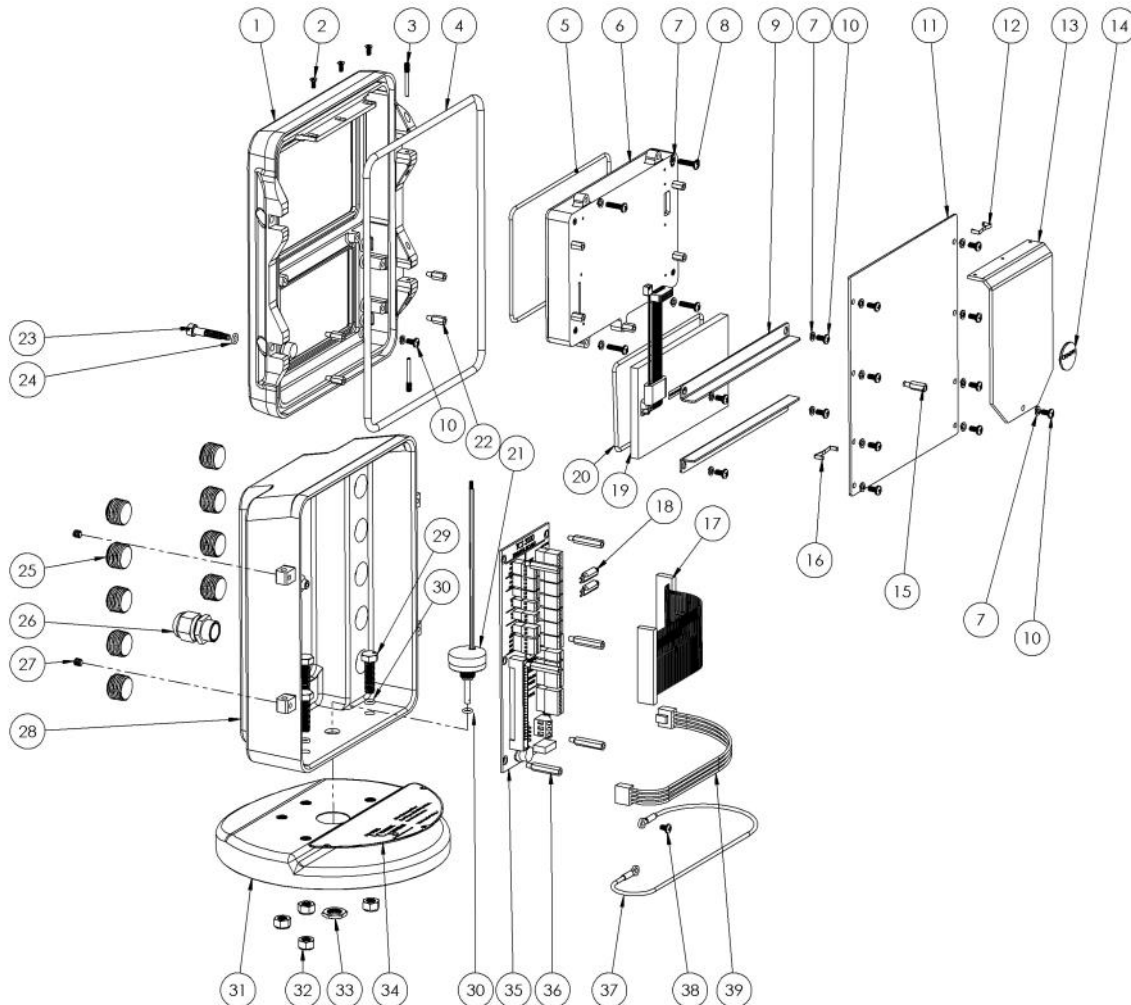

ITEM	PART NO.	DESCRIPTION	QTY.
1	307150	FRONT COVER, 7" DISPLAY	1
2	300122	SKT CNTRS NK SCREW M3X8	3
3	300172	HINGE PIN	2
4	300174	COVER GASKET	1
5	300146	DISPLAY GASKET	1
6	307320	7" DISPLAY ASSEMBLY WITH SCREEN PROTECTOR	1
7	300138	SPRING WASHER, M4	18
8	307137	M4 X 16 PHILLIPS PAN SCREW	4
9	300131	COMPRESSION BAR	2
10	300137	M4 X 8 PHILLIPS PAN SCREW	14
11	307110	PC BOARD ASSEMBLY	1
12	300260	RETAINING CLIP X1 CONNECTOR	1
13	300120	RADIATOR	1
14	300797	REPLACABLE BATTERY	1
15	300225	M4 X 13.59 STANDOFF	1
16	300261	RETAINING CLUP X2 CONNECTOR	1
17	300176	50 PIN X 6" RIBBON CABLE	1
18	300759	RESISTOR WITH SHRINK TUBE	2
19	300230	KEYBOARD ASSEMBLY	1
20	300144	KEYBOARD GASKET	1

ITEM	PART NO.	DESCRIPTION	QTY.
21	300160	PULSER	1
22	300125	STAINOFF	4
23	307156	CALIBRATION SCREW	1
24	307153	CALIBRATION SCREW GASKET	1
25	300252	PLUG, 1/2 NPT	9
26	300133	CORD GRIP, 1/2 NPT, .2-.35 ATEX	1
27	300173	SET SCREW	2
28	300290	90 DEGREE REAR HOUSING, 1/2 NPT	1
29	300212	M8 SCREW WITH O-RING ASSEMBLY	4
30	300206	O-RING	
31	300210	TCS 3000 STAND W/HELICOILS	1
32	300204	M8 LOCKNUT, SS/NYLON	4
33	300162	PULSER NUT, 1/2-32 HEX	1
34	300217	NAMEPLATE	1
35	300112	TERMINAL BOARD W/ CONNECTOR	1
36	300124	M4 X 27 STANDOFF	6
37	300181	6" GROUND WIRE W/ RING TERMINAL	1
38	300151	M4 X 6 PHILLIPS PAN HEAD SCREW	2
39	300177	4 PIN X 9" POWER RIBBON CABLE	1

---

## —Warranty Information

### WARRANTY

New 3000 electronic registers, equipment or components manufactured by Total Control Systems, a division of Murray Equipment, Inc. (TCS) with which this warranty is enclosed, are warranted by TCS to the original purchaser only for a period of TWELVE (12) months from installation or eighteen (18) months from the date of shipment, to be free, under normal use and service, from defects in material and workmanship.

Defects occurring within the stated warranty period, TCS will repair or replace, at TCS's option; provided that part or parts are returned to TCS transportation charges prepaid, and TCS's examination discloses the parts or workmanship to have been defective upon delivery to the purchaser.

### EXCLUSIONS

Warranty does not cover any parts and equipment not manufactured by TCS, but these items may be covered by separate warranties of their respective manufacturers. This warranty does not extend to any equipment that has been subjected to misuse, negligence or accident or if operated in any manner other than in accordance with TCS's operating instructions and specifications.

### CLAIM PROCEDURES

In order to obtain performance by TCS of its obligations under this warranty, the original purchaser must obtain a Return Goods Authorization (RGA) number from TCS's customer service department within 30 days of discovery of a purported breach of warranty, but not later than the expiration of the warranty period. Once authorization is received, return the defective meter, piece of equipment, or component covered by this warranty, with transportation charges prepaid, to TCS at the address shown below together with a written statement setting forth the nature of the defect and RGA number.

### LIMITATIONS

THERE ARE NO OTHER WARRANTIES OF ANY KIND, EXPRESS OR IMPLIED. TCS SPECIFICALLY DISCLAIMS ANY WARRANTY OF MERCHANTABILITY OR OF FITNESS FOR ANY PARTICULAR PURPOSE. TCS will determine if all parts or meter defect falls within the warranty guidelines and will repair or replace within a reasonable time span. TCS is not responsible for any in or out bound freight. TCS's sole obligation that shall represent the buyer's sole and exclusive remedy shall be to repair or at TCS's option to replace any product or part determined to be defective. In no event shall TCS be liable for any special, direct, indirect, incident, consequential or other damages of similar nature, including without limitation, loss of profits, products, production time, or loss of expenses of any nature incurred by the buyer or any third party. TCS has not authorized on its behalf any representation or warranties to be made, nor any liability to be assumed except as expressly provided herein; there is no other express or implied warranty.

### DESIGN AND EQUIPMENT CHANGES

Any changes in design or improvements added shall not create any obligation to install same on equipment previously sold or ordered.



The Standard of Measurement

2515 Charleston Place  
Fort Wayne, IN 46808

Phone: (260) 715-4500  
Fax: (260) 484-9230  
Email: [sales@tcsimeters.com](mailto:sales@tcsimeters.com)  
Website: [www.tcsimeters.com](http://www.tcsimeters.com)